

Guardian 6000 Electrical Safety Analyzer Instruction Manual

Form 150354/A7

©QuadTech, Inc., 2000
5 Clock Tower Place, 210 East
Maynard, Massachusetts, U.S.A. 01754
April 2001

Telephone	978-461-2100
Sales	800-253-1230
Facsimile	978-461-4295
Website	www.quadtech.com

The material in this manual is for informational purposes only and is subject to change, without notice. QuadTech assumes no responsibility for any error or for consequential damages that may result from the misinterpretation of any procedures in this publication.

WARNING

Potentially dangerous voltages may be present on front and rear panel terminals. Follow all warnings in this manual when operating or servicing this instrument. Dangerous levels of energy may be stored in capacitive devices tested by this unit. Always make sure the high voltage indicator is **not** on when connecting or disconnecting the device under test.



Product will be marked with this symbol (ISO#3864) when it is necessary for the user to refer to the instruction manual in order to prevent injury or equipment damage.



Product marked with this symbol (IEC417) indicates presence of direct current.



Product will be marked with this symbol (ISO#3864) when voltages in excess of 1000V are present.

Contents

Warranty	7
Specifications	9
Accessories	13
Safety Precautions	15
Condensed Operating Instructions	17
Introduction - Section 1	
1.1 Unpacking and Inspection	21
1.2 Product Overview	21
1.3 Controls and Indicators	22
1.3.1 Front Panel Controls and Indicators	22
1.3.2 Rear Panel Controls and Connectors	24
1.4 Installation	26
1.4.1 Dimensions	26
1.4.2 Instrument Positioning	26
1.4.3 Power Requirements	26
1.4.4 Safety Inspection	27
Operation - Section 2	
2.1 Terms and Conventions	29
2.2 Start-Up	32
2.3 Programming Hipot Tests	33
2.3.1 Programming an AC Hipot Test	33
2.3.2 Programming a DC Hipot Test	34
2.4 Programming an Insulation Resistance Test	35
2.5 Programming a Ground Bond Test	36
2.6 Programming a Leakage Current Test	37
2.6.1 Simulated Leakage Current	37
2.6.2 True Line Leakage Current (6000-04 installed)	38
2.7 Programming a Multi-Step Test	40
2.8 Storing a Test Setup	41
2.8.1 Storing a Single Step Test	41
2.8.2 Storing a Multi-Step Test	41
2.9 Instrument Zeroing/Offset	42
2.10 Connection To Device Under Test	44
2.11 Measurement Procedure	47
2.12 Initial Parameter Setting	48

Contents (Continued)

2.12.1	General Setting	51
2.12.1.1	Contrast	51
2.12.1.2	Beep Volume	51
2.12.1.3	Scan Number	51
2.12.1.4	Fail Retest	52
2.12.1.5	Print PASS	52
2.12.1.6	Print FAIL	52
2.12.1.7	Timer U/D	52
2.12.2	Timing Setting	52
2.12.2.1	Pass Hold	52
2.12.2.2	Step Hold	52
2.12.2.3	Judgement Wait	52
2.12.2.4	DC Wait	53
2.12.3	Special Setting	53
2.12.3.1	AC-V Freq.....	53
2.12.3.2	G-R Freq	53
2.12.3.3	G-R Volt	53
2.12.3.4	Auto Range	53
2.12.3.5	Software AGC	54
2.12.3.6	Password	54
2.12.3.7	G-R Cont	55
2.12.3.8	Simulation	55
2.12.3.9	IEC601-1	55
2.12.3.10	Lock Rcl	55
2.12.4	Remote Setting	55
2.12.4.1	GPIB Address	55
2.12.4.2	Baud Rate	55
2.12.4.3	GPIB Comp.	56
2.13	Front Panel Lockout	56
2.14	Software Version Display	56
2.15	Clear Setup Memory	57

Interface - Section 3

3.1	Remote	59
3.2	RS232 Interface	62
3.2.1	PIN Configuration	62
3.2.2	RS232 Specifications	63
3.2.3	RS232 Commands	63
3.2.4	Sample QuickBASIC Program.....	64
3.3	IEEE-488 Interface	65
3.3.1	PIN Configuration	65
3.3.2	IEEE-488 Interface Codes and Messages.....	66
3.3.3	IEEE-488 Interface Commands.....	67

Contents (Continued)

3.3.4	Listener Functions	68
3.3.5	Talker Functions	73
3.3.6	Sample QuickBASIC Program	76
3.4	Printer Interface	78
3.5	Scanner Interface	79
3.5.1	Scanner Accessories	79
3.5.2	Scanner Card Installation	80
3.5.3	Scanner Connections	81
3.5.4	External Scanner Programming	82
3.6	G16 International Power Strip.....	85
3.7	G14 Power Entry Adaptor Cable	86
3.8	G13 Corded Product Adaptor	87
 Service & Calibration - Section 4		
4.1	General	89
4.2	Instrument Return.....	89
4.3	Calibration.....	89
4.3.1	Calibration Procedure.....	90
4.3.2	AC Voltage Calibration.....	92
4.3.3	DC Voltage Calibration.....	93
4.3.4	IR Voltage Calibration	94
4.3.5	AC Current Calibration	95
4.3.6	DC Current Calibration	97
4.3.7	Ground Bond Calibration	99
4.3.8	WAC and WDC ARCing Calibration.....	102
4.3.9	Leakage Current Calibration	103
4.3.9.1	Simulated LC Calibration	103
4.3.9.2	True LC Calibration (G6000-04 installed)	104
4.3.10	IR Resistor Calibration	109
4.3.11	Finalize Calibration	111
4.4	Error Messages	111

Warranty



QuadTech warrants that Products are free from defects in material and workmanship and, when properly used, will perform in accordance with QuadTech's applicable published specifications. If within one (1) year after original shipment it is found not to meet this standard, it will be repaired, or at the option of QuadTech, replaced at no charge when returned to a QuadTech service facility.

Changes in the Product not approved by QuadTech shall void this warranty.

QuadTech shall not be liable for any indirect, special or consequential damages, even if notice has been given of the possibility of such damages.

This warranty is in lieu of all other warranties, expressed or implied, including, but not limited to any implied warranty or merchantability or fitness for a particular purpose.

SERVICE POLICY

QuadTech's service policy is to maintain product repair capability for a period of at least five (5) years after original shipment and to make this capability available at the then prevailing schedule of charges.

Specifications

Dielectric Strength

AC Output Voltage:	Range: 0.5 to 5kV AC, in 1V steps Regulation: \pm (1% of setting +5V) Frequency: 50/60Hz selectable
Voltage Display:	Accuracy: \pm (1% of reading +5V) Resolution: 1V steps
AC Current Display:	Total current Range: 1 μ A to 40mA AC, in 1 μ A or 10 μ A steps Accuracy: \pm (1% of reading + 5 μ A or 10 μ A)
DC Output Voltage:	Range: 0.5 to 6kV DC, in 1V steps
Voltage Display:	Accuracy: \pm (1% of reading +5V) Resolution: 1V steps
DC Current Display:	Range: 0.1 μ A to 0.3mA DC, in 0.1 μ A steps 0.3mA to 3mA DC, in 1 μ A steps 3mA to 20mA DC, in 10 μ A steps Accuracy: \pm (1% of reading + 0.5 μ A or 5 μ A or 50 μ A)

Insulation Resistance

Insulation Resistance:	Voltage: 50 - 1000V DC in 1V steps Accuracy: \pm (1% of reading + 5V) Range: 100k Ω - 50G Ω (voltage dependent) Accuracy: \pm 5% \geq 500V, 10M Ω - 1G Ω \pm 10% \geq 500V, 1G Ω - 10G Ω \pm 15% \geq 500V, 10G Ω - 50G Ω \pm 10% < 500V, 100k Ω - 1G Ω
-------------------------------	---

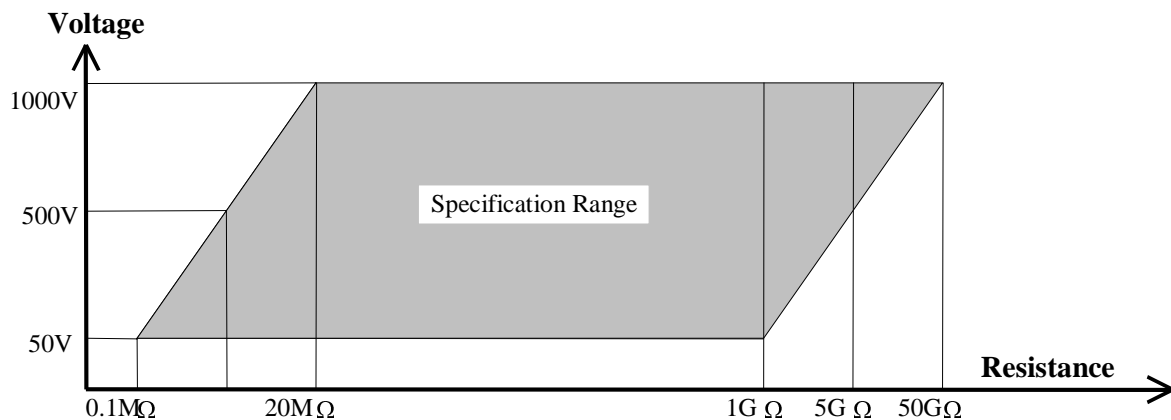

Specifications (Continued)

Ground Bond

Output Current:	Range:	1.0 to 30.0A AC, setting 0.1A/step
	Accuracy:	$\pm (1\% \text{ of setting} + 0.3\text{A})$ $\pm (1\% \text{ of reading} + 0.5\text{A})$
	Frequency:	50/60Hz, 6 to 15V
Resistance:	Range:	0.1m Ω - 510.0m Ω , 4 digits, Hi Limit
	Accuracy:	$\pm (1\% \text{ of reading} + 0.5\text{m}\Omega)$

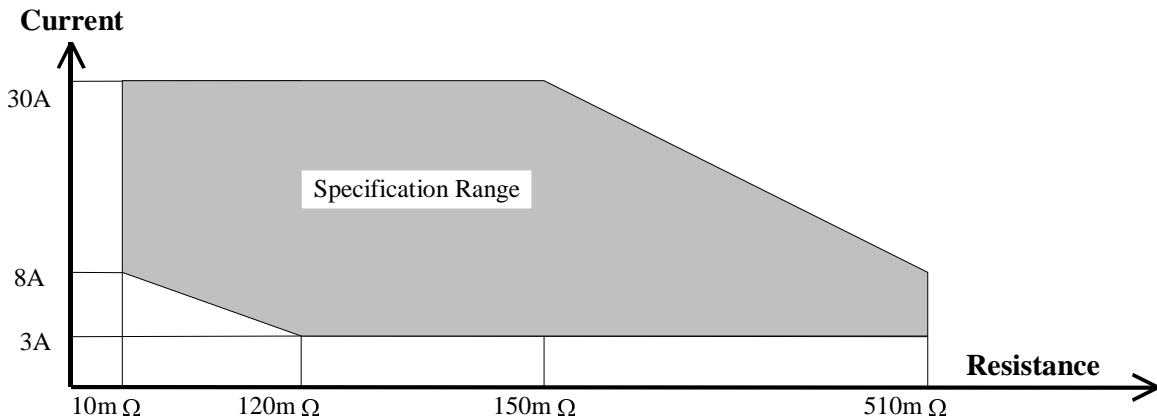

Leakage Current

Test Voltage:	Range:	0.05 – 0.4kV AC, Constant Voltage
	Accuracy:	$\pm (1\% \text{ of reading} + 5\text{V})$
Cutoff Current:	Range:	0.01mA – 9.999mA AC, 3 μ A resolution
	Accuracy:	$\pm (1\% \text{ of reading} + 5 \text{ counts})$

ARC Detection

Detection Current:	Range:	1mA – 40mA AC, 1mA – 20mA DC
Pulse Width:	Minimum:	10 μ s
Level:	AC:	0.01mA – 0.5mA for Hi limit set $\leq 0.5\text{mA}$
		0.1mA – 40mA for Hi limit set $> 0.5\text{mA}$
	DC:	0.01mA – 0.2mA for Hi limit set $\leq 0.2\text{mA}$
		0.1mA – 20mA for Hi limit set $> 0.2\text{mA}$

Specifications (Continued)

General Features

Limits:	Hi/Lo Programmable during Test Time (Lo can be set to Off for Hipot & GR, Hi can be set to Off for IR) Hi/Lo Programmable during Ramp Time (AC/DC Hipot only) (Both limits can be set to OFF)
Indication:	Pass/fail LEDs, audible sound
Buzzer Level:	1,2,3, OFF
Time:	AC Hipot: Ramp, Test: 0.1 to 999sec (± 20 ms) DC Hipot: Ramp, Test: 0.1 to 999sec (± 20 ms) IR: Ramp, Test: 0.1 to 999sec (± 20 ms) GC: Test: 0.1 to 999sec (± 20 ms) LC: Test: 0.1 to 999sec (± 20 ms) (Test can be set to Continuous. Ramp & Dwell can be set to OFF)
Remote Control:	Inputs: START, RESET Characteristics: 24V active low, Pulse width >1ms Outputs: PASS, FAIL, UNDER TEST Characteristics: Dry contact relay, Closed if true 120V, 100mA max Connector: 9 pin male D-series & Terminal Strip
Setup Storage:	50 Memory Groups (include 10 steps each)
Standard Interfaces:	IEEE-488 Scanner
Optional Interfaces:	RS232 Printer (replaces IEEE-488)
Optional Internal Scanner:	8 Channel Plug-In Scan Unit: 3GC/5HV, 5GC/3HV, or 8HV Channels 4 Channel Plug-In True Line Leakage Scan Unit : 2HV/2GC Channels
Connectors:	Front and Rear Connection
Front Panel Lockout:	6 Digit Password with or without setup recall LED Display "KeyLock"

Specifications (Continued)

General Features

Mechanical: Bench Mount (optional rack mount flanges available, G-27)
Dimensions:(w x h x d):16.875 x 5.625 x 20.50 inches
421.875 x 140.625 x 512.50 mm

Weight: 52 lbs (24kg) net, 69 lbs (32kg) shipping

Environmental: Meets MIL-T-28800E, Type 3, Class 5
Operating: 0°C to + 40°C
Storage: -20° to + 70°C
Humidity: <75%
Warm-up Time: 15 minutes

Power:

• 90 - 130V AC	• 50 or 60Hz
• 200 - 250V AC	• 500W max

Supplied:

• Instruction Manual	• Power Cable
• Calibration Certificate	• Test Leads (3)

Ordering	<u>Description</u>	<u>Catalog No.</u>
Information:	AC/DC/IR/GC Safety Analyzer	Guardian 6000

Accessories

Accessories Included

Item	Quantity	QuadTech P/N
IEEE-488 ('GPIB') Interface (Standard/Installed)	1	700081
Scanner ('SCAN') Interface (Standard/Installed)	1	700120
AC Power Cord	1	4200-0300
Power Line Fuse 6.3A 250V SB	1	520071
Power Line Fuse 3.15A 250V SB	1	520072
High Voltage Lead Set, 1m with alligator clips	1	S02
Ground Continuity Test Lead Set with spring clips	1	G15
Ground Continuity Power Entry Adaptor Cable	1	G14
Instruction Manual	1	150354
Calibration Certificate	1	N/A

Accessories/Options Available

Item	Quantity	QuadTech P/N
High Voltage Lead Set, high & low, 1m (std. with unit)	1	S02
High Voltage Lead Set, high & low, 2m	1	S04
High Voltage Lead, 1m, unterminated	1	S09
High Voltage Lead, 2m, unterminated	1	S10
Foot Switch	1	S05
High Voltage Probe	1	S06
Gun Probe	1	S08
Gun Probe with Remote Start	1	S11
Load Box, resistive	1	S12
Load Box, custom resistors	1	S14
Corded Product Adaptor, 115V (used for GB test)	1	G13
Corded Product Adaptor, 240V (used for GB test)	1	G25
Corded Product Adaptor, 115V (used for LC test)	1	G30
Power Entry Adaptor Cable, GC (std. with unit)	1	G14
Ground Continuity Lead Set (std. with unit)	1	G15
International Power Strip	1	G16
Rack Mount Flanges	1	G27
RS232 Interface	1	G26
Printer Interface (Replaces IEEE-488 Interface)	1	G28
850085 8-Channel plug-in Scanner, 3GC/5HV	1	6000-01
850084 8-Channel plug-in Scanner, 5GC/3HV	1	6000-02
850083 8-Channel plug-in Scanner, 8HV	1	6000-03
850100 4-Channel plug-in Scanner: True Line Leakage	1	6000-04
Isolation Transformer 500VA (used with 6000-04)	1	G31
Isolation Transformer 1000VA (used with 6000-04)	1	G32

Safety Precautions

The Guardian 6000 Electrical Safety Analyzer can provide an output voltage as high as 6000VDC (5000VAC) to the external device under test (DUT). Although the Guardian unit is designed with full attention to operator safety, serious hazards could occur if the instrument is used improperly and these safety instructions are not followed.

1. The Guardian 6000 unit is designed to be operated with its chassis connected to earth ground. The instrument is shipped with a three-prong power cord to provide this connection to ground. This power cord should only be plugged in to a receptacle that provides earth ground. Serious injury can result if the Guardian 6000 is not connected to earth ground.
2. Tightly connect cable(s) to the (black) **Drive-** terminal. If this is not done, the DUT's casing can be charged to the high voltage test level and serious injury or electrical shock hazards could result if the DUT is touched.
3. Never touch the metal of the High Voltage probe directly. Touch only the insulated parts of the lead(s).
4. Never touch the test leads, test fixture or DUT in any manner (this includes insulation on all wires and clips) when the high voltage is applied and the red **DANGER** light is **ON**.
5. Before turning on the Guardian unit, make sure there is no device (DUT) or fixture connected to the test leads.
6. After each test, press the **[STOP]** (red) button for safety. This terminates the high voltage being applied to the output terminals.
7. When the red **DANGER** LED is lit or flashing, NEVER touch the device under test, the lead wires or the output terminals.
8. Before touching the test lead wires or output terminals make sure :
 - a) The red **[STOP]** button has been pressed
 - b) The red **DANGER** LED is **OFF**.
9. **In the case of an emergency**, turn OFF the POWER switch using a "hot stick" and disconnect the AC power cord from the wall. DO NOT TOUCH THE Guardian 6000 INSTRUMENT.
10. If the **DANGER** LED does not go **off** when the **[STOP]** button is pressed, immediately stop using the tester. It is possible that the output voltage is still being delivered regardless of the TEST ON/OFF control signal.
11. When the Guardian 6000 instrument is used in remote control mode, be extremely careful. The High Voltage Output is being turned on and off with an external signal.

Condensed Operating Instructions

WARNING

High Voltage is applied to the white **H.V. OUTPUT** Terminal anytime the red **DANGER LED** is ON or flashing. Always make sure the **DANGER LED** is OFF when connecting or disconnecting the Device Under Test (DUT).

General Information

The Guardian 6000 Electrical Safety Analyzer is a measuring instrument for direct readout of Hipot output voltage and leakage current, insulation resistance and ground bond. The voltage applied to the device under test is adjustable from 50V to 5kVAC and 50V to 6kVDC. The current limit is adjustable from 1 μ A to 40mA AC in 1 μ A or 10 μ A steps and 0.1 μ A to 20mA DC in 0.1 μ A, 1 μ A or 10 μ A steps. PASS and FAIL LEDs provide a visual display of test results based on preset limits.

Start-Up

The Guardian 6000 unit can be operated from a power source between 90 and 250VAC at a power line frequency of 50 or 60Hz. The standard Guardian 6000 unit is shipped from QuadTech with a 6.3A fuse in place for AC 90-130V operation. (A 3.15A fuse is included for 200-250V operation). The G6000 unit is shipped with the line voltage selector set for 120V. Refer to paragraph 1.4.3 to change a fuse and to change the line voltage selector.

Connect the Guardian 6000 unit AC power cord to the source of proper voltage. The Guardian 6000 is designed to be operated with its chassis connected to earth ground. The Guardian 6000 is shipped with a three prong power cord to provide this connection to ground. This power cord should only be plugged in to a receptacle which provides earth ground. Serious injury can result if the Guardian 6000 is not connected to earth ground.

Press the [POWER] button on the front panel to apply power. To switch the power off press the [POWER] button again or if measurements are to be made proceed with Test Parameter Set-Up below. **Note:** the G6000 unit should warm-up for 15 minutes prior to use.

Test Parameter Set-Up

Press [PROG] and enter the Test Parameters according to your test specification.

Test	Test Mode	V (KV)	IR HI R (M Ω) GR (m Ω)	IR LO R (M Ω) GR (m Ω)	I HI Limit (mA) GR	I LO Limit (mA)	ARC Detect (mA)	Test Time (sec)	Ramp Time (sec)
AC Hipot	SET	SET			SET	SET	SET	SET	SET
DC Hipot	SET	SET			SET	SET	SET	SET	SET
Insulation Resistance	SET	SET	SET	SET				SET	SET
Ground Continuity	SET	SET	SET	SET	SET			SET	

Condensed Operating Instructions

NOTE

Refer to paragraphs 2.3.1, 2.3.2, 2.4, 2.5, 2.6 and 2.7 for a full description of programming test parameters and instruction on how to store the test setup. Test parameters must be set **before** the G6000 unit can be zeroed.

Zeroing/Offset

After setting your test parameters, zero the Guardian 6000 unit by using the automatic offset. **With no device connected**, connect the appropriate cable (or other fixture) into the front panel OUTPUT connectors. Refer to paragraph 2.9 for cable connections based on tests to be made. Test leads for AC Hipot, DC Hipot and IR measurements should be OPEN and test leads for GR should be SHORTED.

Press the [OFFSET] key once. Display reads "Offset is GET. Press Test Key". Press the [TEST] key once. Display shows your test set-up. Press the [OFFSET] key once. Display shows your offset. Offset has to be recalculated each time you change your test parameters, test leads or test fixture.

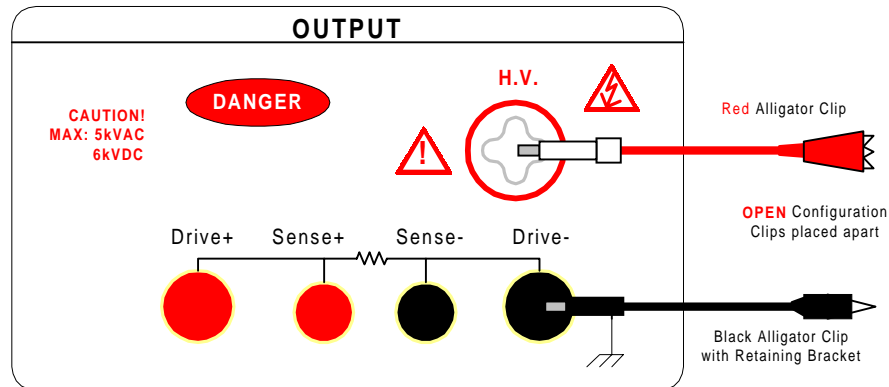

Figure COI-1: Zero/Offset OPEN Configuration

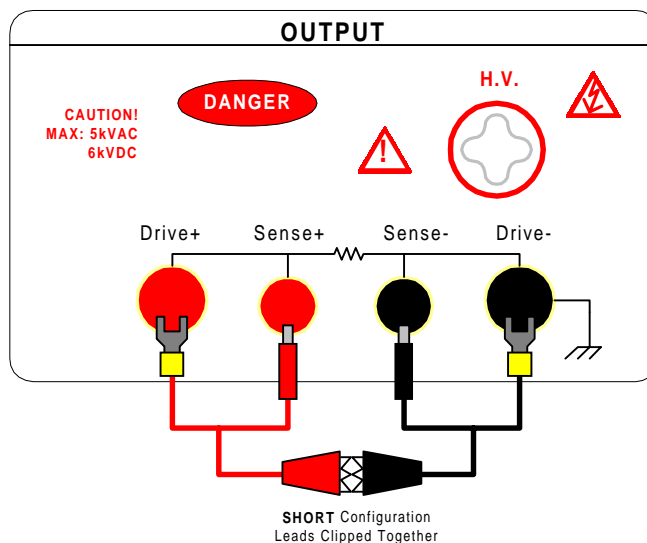

Figure COI-2: Zero/Offset SHORT Configuration

Condensed Operating Instructions

Measurement Mode

The G6000 Electrical Safety Analyzer is capable of measuring AC Hipot, DC Hipot, Insulation Resistance, Leakage Current and Ground Bond. Refer to paragraph 2.9 for the appropriate cable connection to the device under test. Refer to paragraphs 2.3.1, 2.3.2, 2.4, 2.5, and 2.6 for instruction on programming a test listed above.

AC Hipot Measurement Example:

- 1 Turn Power ON.
- 2 Let Guardian 6000 unit warm-up 15 minutes.
- 3 Connect Black ground cable to Guardian 6000 **Drive-** terminal.
- 4 Connect Red high voltage cable to Guardian 6000 **H.V.** terminal.
- 5 Press [PROG] and enter your Test Parameters Press [PROG] again to accept it.
- 6 [STORE] Test set-up (If desired).
- 7 Zero the Guardian 6000 unit (OFFSET).
- 8 Connect Device Under Test (DUT).
- 9 Press red [STOP] button.
- 10 Press green [TEST] button.
- 11 Record Readings.
- 12 Press red [STOP] button.

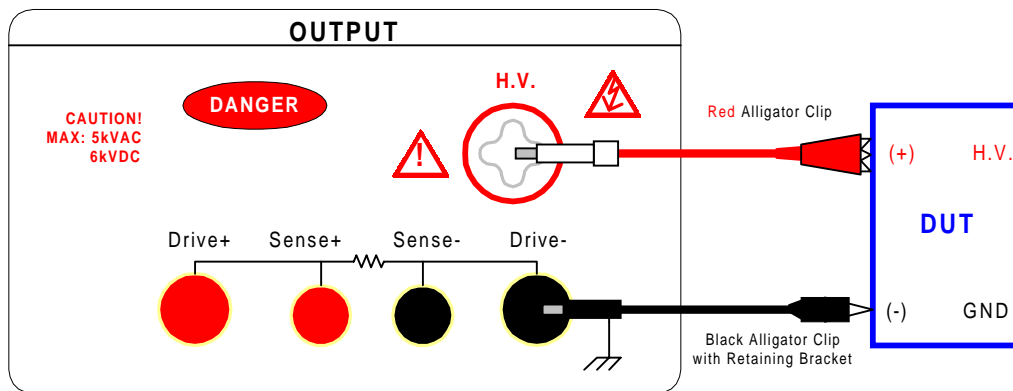

Figure COI-3: S02 Cable Connection To Device Under Test

Section 1 : Introduction

1.1 Unpacking and Inspection

Inspect the shipping carton before opening. If damaged contact the carrier agent immediately. Inspect the Guardian 6000 instrument for any damage. If the instrument appears damaged or fails to meet specifications notify QuadTech (refer to instruction manual front cover) or its local representative. Retain the shipping carton and packing material for future use such as returning for recalibration or service.

1.2 Product Overview

The Guardian 6000 Safety Analyzer combines five critical safety tests into a single instrument, these being **AC hipot, DC hipot, insulation resistance, leakage current and ground bond measurements**. The hipot test can be programmed over a voltage range of 0.05 to 5kV AC and 0.05 to 6kV DC with a min/max leakage current detection range of 1 μ A to 40mA AC and 0.1 μ A to 20mA DC. Insulation resistance measurements are possible to 50G Ω at programmable DC test voltages between 50 and 1000V. A ground bond test to 30A AC is also possible. The instrument comes standard with internal storage of up to 50 memory groups, an IEEE-488.2 interface for remote control operation and communication with other instrumentation and a Scanner interface for multi-point testing.

WARNING

The Guardian 6000 Electrical Safety Analyzer is capable of generating extremely HIGH VOLTAGE up to 6000VDC.

Do NOT touch the Test Terminals when the red DANGER LED is ON.

Always make sure the DANGER LED is OFF when connecting or disconnecting the device under test (DUT).

1.3 Controls and Indicators

1.3.1 Front Panel Controls and Indicators

Figure 1-1 illustrates the controls and indicators on the front panel of the Guardian 6000. Figure 1-2 is a detailed illustration of the key pad (4a-y of Figure 1-1). Table 1-1 identifies the controls and indicators with descriptions and functions.

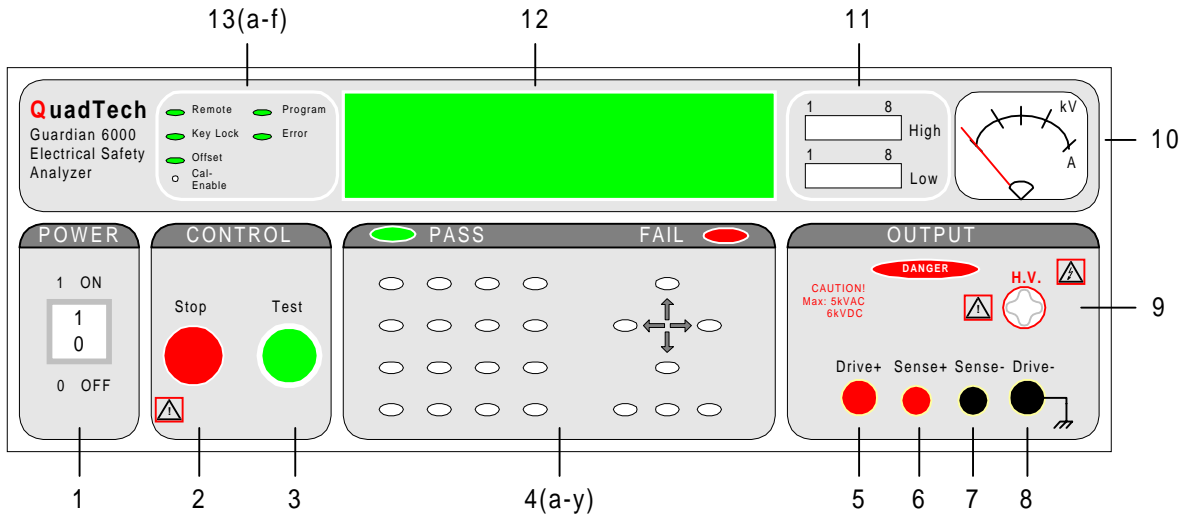
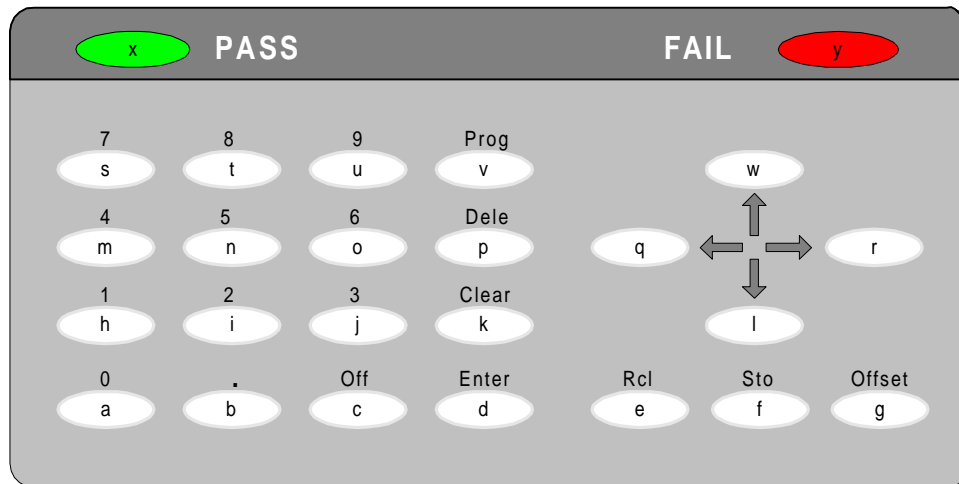

Figure 1-1: G6000 Front Panel Controls & Indicators



NOTE: The lower case letters inside the white buttons are for identification purposes only. They do **NOT** appear on the instrument.

Figure 1-2: Close-Up G6000 Key Pad (4a-y)

Table 1-1 : G6000 Front Panel Controls and Indicators

Reference Number Figures 1-1 and 1-2	Name	Type	Function
1	POWER	White Toggle Switch	Applies AC power to unit, 0=OFF, 1=ON
2	Stop	Red Push Button	Stops the test in progress. Reset function : Stop MUST be pressed before green Test button.
3	Test	Green Push Button	Starts a test and applies high voltage to the Test Terminals.
4	Key Pad	White Push Buttons	To program test information.
4a	0	White P-B	Numerical key
4b	.	White P-B	Decimal key
4c	Off	White P-B	Turn test parameters OFF (limits, arc)
4d	Enter	White P-B	To enter test parameters
4e	Rcl	White P-B	To recall stored test parameters (1-50) from memory
4f	Sto	White P-B	To store test parameters (1-50) from memory
4g	Offset	White P-B	To initiate zeroing (offset) function
4h	1	White P-B	Numerical key
4i	2	White P-B	Numerical key
4j	3	White P-B	Numerical key
4k	Clear	White P-B	To cancel parameter number and input again
4l	↓	White P-B	To examine steps 1-15, To ↓ test voltage, To change status
4m	4	White P-B	Numerical key
4n	5	White P-B	Numerical key
4o	6	White P-B	Numerical key
4p	Dele	White P-B	To delete a test step, those below move up
4q	←	White P-B	Under PROG, To select parameter for programming
4r	→	White P-B	Under PROG, To select parameter for programming
4s	7	White P-B	Numerical key
4t	8	White P-B	Numerical key
4u	9	White P-B	Numerical key
4v	Prog	White P-B	To enter and exit parameter setting status
4w	↑	White P-B	To examine steps 1-15, To ↑ test voltage, To change status
4x	PASS	Green LED	When lit, indicates PASS result of programmed test
4y	FAIL	Red LED	When lit, indicates FAIL result of programmed test
5	Drive+	Red Female Recptacle	High Current Terminal (Driver) for Ground Bond Test
6	Sense+	Red Female Recptacle	High Voltage Terminal (Sense) for Ground Bond Test
7	Sense-	Black Female Recptacle	Low Voltage Terminal (Sense) for Ground Bond Test
8	Drive-	Black Female Receptacle	Ground Reference for ALL Tests
9	H.V.	White Female Receptacle	High Voltage Output Terminal (Hipot, IR & Leakage Curr.)
10	Meter	Analog KV, A units	Indicates output voltage and current
11	Scanner	Two bars of 8 LEDs each	Indicate which scanner outputs are High or Low
12	Display		Indicates step, mode, limits, test setup, test result
13a	Remote	Green LED	When lit indicates Remote test being performed
13b	Key Lock	Green LED	When lit, indicates the key pad is locked out
13c	Offset	Green LED	When lit, indicates Offset is ON
13d	Program	Green LED	When lit, indicates Program function enabled
13e	Error	Green LED	When lit, indicates Error in entering test information
13f	Cal Enable	Pin sized hole	Used by Qualified Service Personnel for unit calibration

1.3.2 Rear Panel Controls and Indicators

Figure 1-3 illustrates the controls and indicators on the rear panel of the Guardian 6000. Figure 1-4 is a detailed illustration of the two remote connectors on the rear panel of the Guardian 6000. Table 1-2 identifies them with description and function.

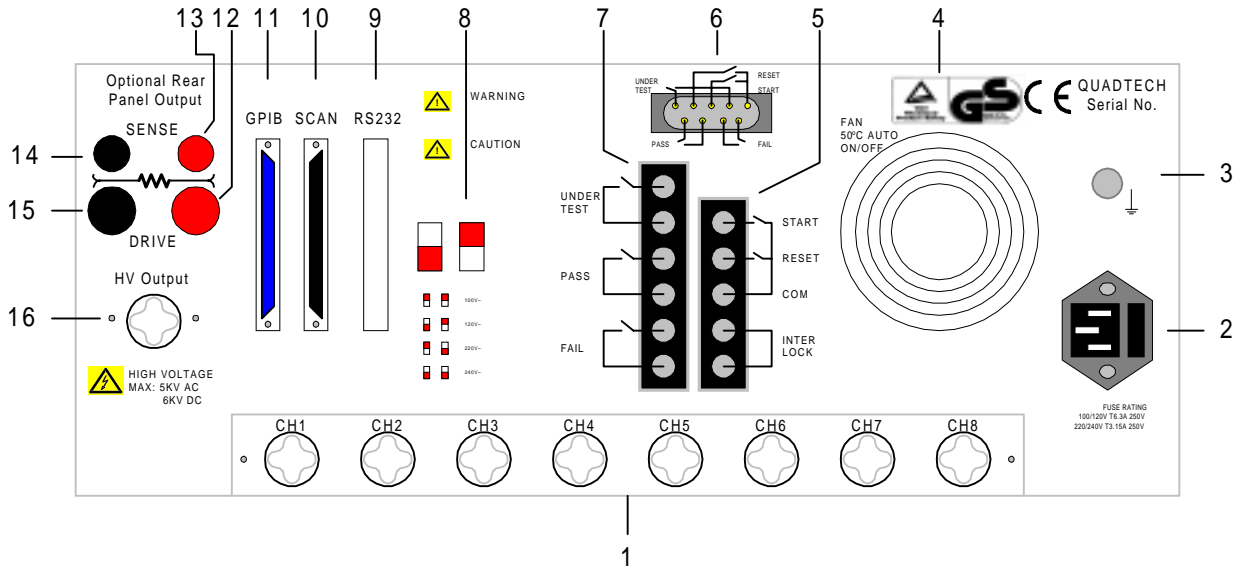

Figure 1-3: G6000 Rear Panel Controls and Connectors

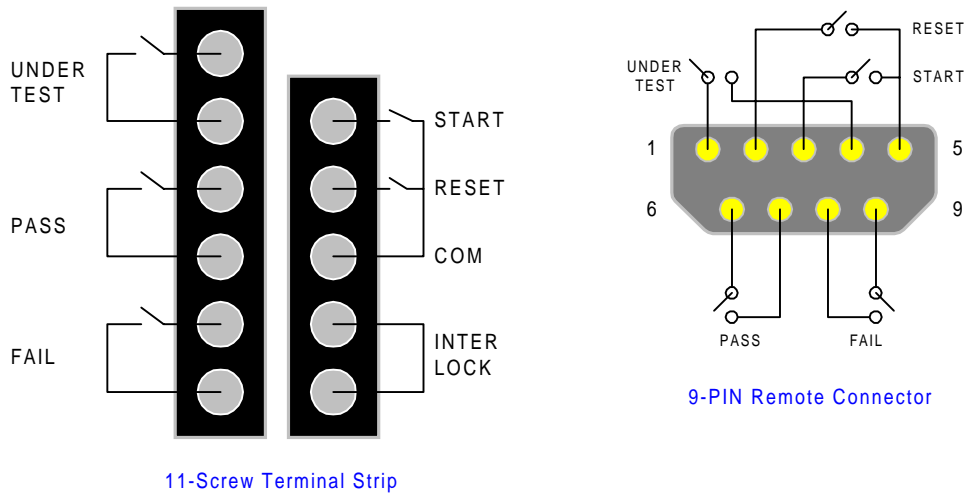

Figure 1-4: Detail G6000 Remote Connectors

Table 1-2: G6000 Rear Panel Connectors and Controls

Reference Number Figure 1-3	Name	Type	Function
1	SCAN UNIT	White Female Receptacle (8)	Inputs for up to 8 DUT's (Optional Accessory: Scan Unit 6000-03 shown 8 HV Channels).
2	AC Inlet Module	Black 3-prong receptacle and fuse drawer	Fuse drawer and 3-wire connection for AC power Source. 6.3A 250V 100-120 operation, 3.15A 250V 220-240 operation.
3	GROUND	Silver screw	Chassis ground connection
4	FAN	Temp Control Fan	To cool unit : ON $\geq 50^{\circ}\text{C}$, OFF $< 50^{\circ}\text{C}$
5	REMOTE INPUT	Black 5 screw relay strip	Remote input signals : START, RESET, COM & INTER LOCK
6	REMOTE	Silver 9 pin D-Type Connector	Remote control connections
7	REMOTE OUTPUT	Black 6 screw relay strip	Remote output signals : UNDER TEST, PASS, & FAIL
8	Voltage Selector	Red 2-position DIP Switches (2)	Switches for selecting range of AC power source: Set to 100V for 90-100VAC operation Set to 120V for 110-130VAC operation Set to 220V for 200-220VAC operation Set to 240V for 220-250 VAC operation
9	RS232	Black 25 pin D-Type Connector	Input/Output connections for RS232 Interface
10	SCAN	Black 25 pin D-Type Connector	Input/Output connections for Scanner Interface
11	GPIB	Blue 24 pin connector	Input/Output connections for IEEE-488 or Printer
12	DRIVE +	Red Female Receptacle	Optional Rear Panel Output High Current GR Test
13	SENSE +	Red Female Receptacle	Optional Rear Panel Output High Voltage GR Test
14	SENSE -	Black Female Receptacle	Optional Rear Panel Output Low Voltage GR Test
15	DRIVE -	Black Female Receptacle	Optional Rear Panel Output Ground Ref. for all Tests
16	HV OUTPUT	White Female Receptacle	Optional Rear Panel Output High Voltage Output for Hipot & IR Tests

1.4 Installation

1.4.1 Dimensions

The Guardian 6000 instrument is supplied in bench configuration (a cabinet with resilient feet for placement on a table). Flip feet are provided under the front feet so that the unit can be tilted back for convenient operator viewing.

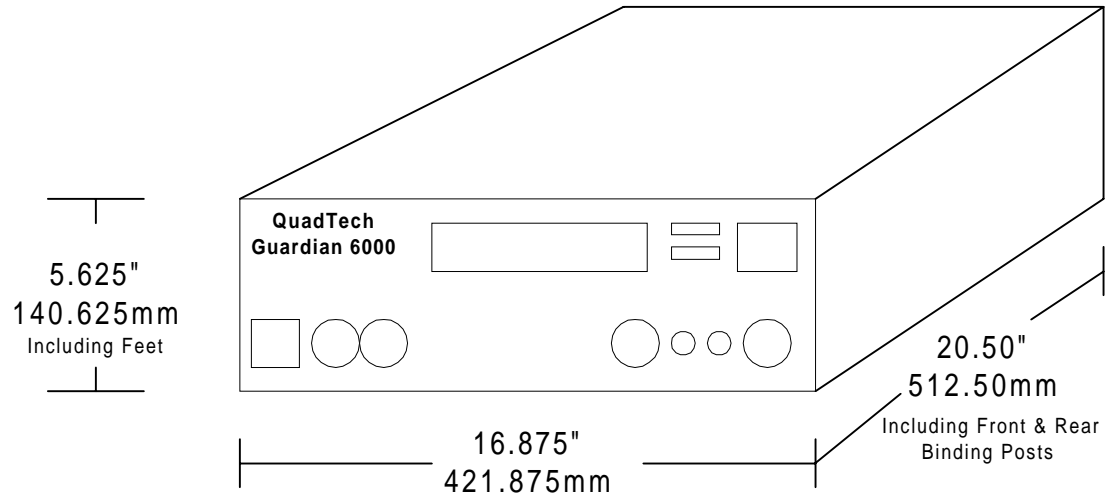



Figure 1-5: G6000 Instrument Dimensions

1.4.2 Instrument Positioning

The Guardian 6000 Safety Analyzer contains a digital display and an analog meter for direct readout of the measured parameters. The optimum viewing angle is slightly down and about 10° either side of center. For bench operation the front flip feet should always be used to angle the instrument up. In bench or rack mount applications the instrument should be positioned with consideration for ample air flow around the rear panel fan ventilation hole. An open space of at least 3 inches (75mm) is recommended behind the rear panel.

1.4.3 Power Requirements

 The Guardian 6000 can be operated from a power source of 90 to 130 VAC or 200 to 250 VAC. Power connection is via the rear panel through a standard receptacle. Before connecting the 3-wire power cord between the unit and AC power source make sure the voltage selection switches on the rear panel (Figure 1-6) and fuses are in accordance with the power source being used. 6.3A, 250V, 5x20mm, for 90-130V source and 3.15A, 250V, 5x20mm, for 200-250V source. Always use an outlet which has a properly connected protection ground.

Procedure for Changing A Guardian 6000 Fuse

WARNING
MAKE SURE THE UNIT HAS BEEN DISCONNECTED FROM ITS AC POWER SOURCE FOR AT LEAST 5 MINUTES BEFORE PROCEEDING.

Remove the fuse drawer, by inserting a flat head screwdriver behind the small tab located just below the 3 prong receptacle, and force outward.

Once the fuse drawer has been removed from the instrument snap the fuse from the holder and replace. Make sure the new fuse is of the proper rating. Note that the fuse drawer can also be used to store a spare fuse.

Install the fuse drawer back in the inlet module (fuse down) by pushing in until it locks securely in place.

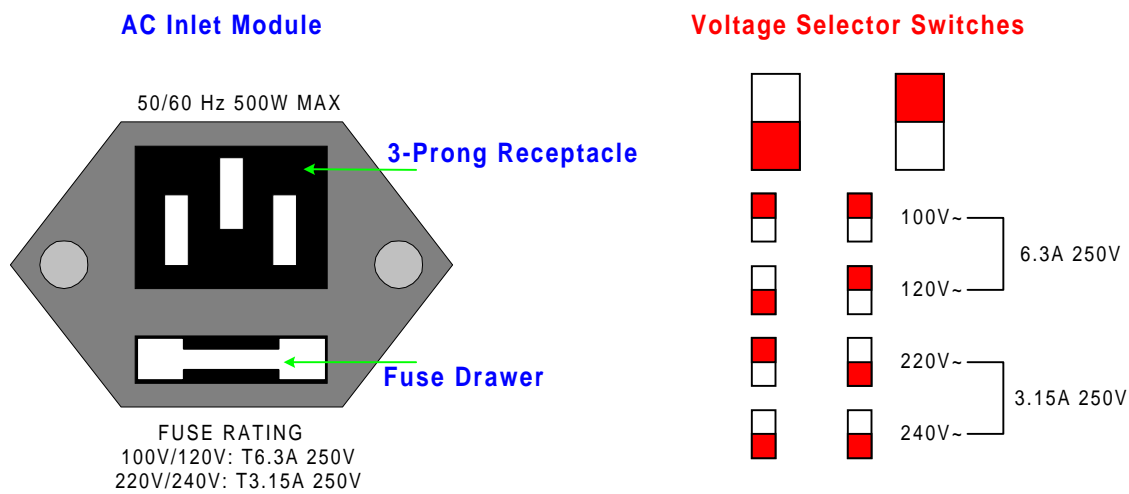



Figure 1-6: AC Inlet Module & Voltage Selector Switches

1.4.4 Safety Inspection

 Before operating the instrument inspect the power inlet module on the rear of the Guardian 6000 to ensure that **the properly rated fuse is in place**, otherwise damage to the unit is possible. Refer to paragraph 1.4.3.

The Guardian 6000 is shipped from QuadTech with a standard U.S. power cord, QuadTech P/N 4200-0300 (with Belden SPH-386 socket or equivalent and 3-wire plug conforming to IEC 320). Make sure that the instrument is used only with these cables (or approved international cord set) to ensure that the instrument is provided with **connection to protective earth ground**.

The surrounding environment should be free from excessive dust to prevent contamination of electronic circuits. The surrounding environment should also be free from excessive vibration. Do not expose the Guardian 6000 unit to direct sunlight, extreme temperature or humidity variations, or corrosive chemicals.

Section 2 : Operation

2.1 Terms and Conventions

Table 2-1 : Measurement Unit Prefixes

<u>Multiple</u>	<u>Scientific</u>	<u>Engineering</u>	<u>Symbol</u>
1000000000000000	10 ¹⁵	Peta	P
1000000000000	10 ¹²	Tera	T
1000000000	10 ⁹	Giga	G
1000000	10 ⁶	Mega	M
1000	10 ³	Kilo	k
.001	10 ⁻³	milli	m
.000001	10 ⁻⁶	micro	u
.000000001	10 ⁻⁹	nano	n
.000000000001	10 ⁻¹²	pico	p
.000000000000001	10 ⁻¹⁵	femto	f

Dielectric Strength: The ratio between the voltage at which breakdown of the insulating material occurs and the distance between the two points subject to the applied voltage.

Dielectric Absorption: The physical phenomenon in which insulation appears to absorb and retain an electrical charge slowly over time. Apply a voltage to a capacitor for an extended period of time, then quickly discharge it to zero voltage. Leave the capacitor open circuited for a period of time then connect a voltmeter to it and measure the residual voltage. The residual voltage is caused by the dielectric absorption of the capacitor.

Charging Current: An insulated product exhibits the basic characteristics of a capacitor. Application of a voltage across the insulation causes a current to flow as the capacitor charges. This current instantaneously rises to a high value as voltage is applied then exponentially decays to zero as the DUT becomes fully charged. Charging current decays to zero much faster than dielectric absorption.

Leakage Current: The steady state current that flows through the insulation. Leakage current is equal to the applied voltage divided by the insulation resistance. Leakage current is the main measured value for AC hipot and DC hipot.

Leakage Current Test:	A line voltage leakage current test simulates the effect of a person touching exposed metal parts of a product and detects whether or not the leakage current that flows through the person's body remains below a safe level. Line leakage tests are conducted by applying power to the product being tested, then measuring the leakage current from any exposed metal on the chassis of the product under various fault conditions such as "no ground". A special circuit is used to simulate the impedance of the human body.
Discharge:	The act of draining off an electrical charge to ground. Devices that retain charge should be discharged after an IR or DC HiPot test.
Insulation Resistance:	Measures the total resistance between any two points separated by electrical insulation. The IR test determines how effective the dielectric (insulation) is in resisting the flow of electrical current.
ARCIing:	Sparking or 'flashing over' caused by a breakdown of electrical insulation.
RAMPing:	The gradual increase or decrease of voltage or current over a period of time (step).
Frequency:	The rate at which current or voltage reverses polarity and then back again completing a full cycle, measured in Hertz (Hz) or cycles/second. AC Line Frequency = 50/60 Hz.
Ground:	The base reference from which voltages are measured, nominally the same potential as the earth. Also the side of a circuit that is at the same potential as the base reference.
Ground Continuity Test:	Test to verify that all conductive parts of a product that are exposed to user contact are connected to the power line ground. GC Test normally performed with a low current DC signal that checks to ensure the ground connection has a resistance of $<1\Omega$.

Ground Bond Test:	Test to verify that all conductive parts of a product that are exposed to user contact are connected to the power line ground. The ground bond test is similar to the ground continuity test. The main difference is that the ground bond test verifies the integrity of the ground connection using a high current AC signal with current level as high as 30Amps. Ground bond provides a better simulation of how a product will perform under an actual fault condition.
Mode:	The test which is to be performed such as AC Hipot (WAC), DC Hipot (WDC), Insulation Resistance (IR), Ground Bond (GR) or Leakage Current (LC).
Step:	The Guardian 6000 can perform up to 10 tests in a sequence. The step number indicates in which order the tests will be performed. For example if step 1 is a ground bond test, step 2 an AC hipot and step 3 an insulation resistance measurement then when a test is started the Guardian 6000 will perform a ground bond test followed by an AC hipot then an insulation resistance measurement.
High Limit:	The high limit is the upper value for a test to be considered a pass. If the measured value is higher than the high limit the test is considered a fail. In hipot, leakage current and ground bond modes a high limit is required.
Low Limit:	The low limit is the lower value for a test to be considered a pass. If the measured value is lower than the low limit the test is considered a fail. In insulation resistance mode a low limit is required.

2.2 Startup

Check to make sure the Red Voltage Selector Switches on the rear panel agree with the power source available. Depending on the power source the switch positions should be in the up or down positions as shown in Figure 1-6 (AC Inlet Module & Voltage Selector Switches).

WARNING
NEVER TOUCH THE TEST LEADS IN ANY MANNER (this includes insulation on all wires and clips) when the **HIGH VOLTAGE IS APPLIED** and red **DANGER LED** is **ON**.
USE ALL PRECAUTIONS NECESSARY TO AVOID TOUCHING THE DEVICE UNDER TEST
WHEN THE RED DANGER LED IS ON OR FLASHING.

Connect the instrument power cord to the source of proper voltage. **The instrument is to be used only with three wire grounded outlets.**

Power is applied to the Guardian 6000 by pressing the white [POWER] toggle switch on the front panel to ON (1 position). The Guardian 6000 unit should have a warm-up time of at least 15 minutes prior to use.

WARNING
DO NOT TURN INSTRUMENT POWER ON OR OFF WITH TEST DEVICES CONNECTED.

Operation with Internal/External Scanner

If the 6000 instrument is equipped with an internal or external scanner, then the scanner channels must be programmed for an AC hipot, DC hipot, insulation resistance, ground bond and leakage current test. When an internal and/or external scanner is connected to the Guardian 6000 instrument, two additional display screens appear during programming. Refer to Figure 2-1. Use the numerical keypad to enter which channel or channels have HV (High) or GROUND (Low) applied during the test. If “disable” is selected, the scanner will not be used. The instruction “Select Scanner Disable” prompts the user to define which of the 8 scanner channels are high or low per scan box. The internal scanner is defined as Scan Box 1. Scan Box 2 is the first external scanner. Scan Box 3 is the second external scanner. Up to 7 external scanners can be added for a total of 64 channels. Refer to paragraph 3.3 for external scanner programming.

High =Disable Scan Box-Channel 1	Low = Disable Scan Box-Channel 1
-------------------------------------	-------------------------------------

Figure 2-1: Scanner Programming Display

2.3 Programming Hipot Tests

2.3.1 Programming an AC Hipot Test

Press [PROG]		Select Step = 1 1-10 (UP/DOWN)
Select Test Step	Press UP or DOWN arrow key to enter test step	
Press [ENTER]		Select Mode = WAC Press UP/DOWN
Select Test MODE	Press UP arrow key to display WAC	
Press [ENTER]		High =Disable Scan Box-Channel 1
Select Scanner Disable*	Press Numerical keys to enter high scanner channels	
Press [ENTER]		Low = Disable Scan Box-Channel 1
Select Scanner Disable*	Press Numerical keys to enter low scanner channels	
Press [ENTER]		Voltage = 0.000KV 0.05-5KV
Select Test Voltage (KV)	Press Numerical & Decimal keys to enter test voltage	
Press [ENTER]		High Limit = 0.500mA 0.001-40mA
Select High Limit (mA)	Press Numerical & Decimal keys to enter high current limit	
Press [ENTER]		Low Limit = Disable 0-40mA 0 = Disable
Select Low Limit (mA)	Press Numerical & Decimal keys to enter low current limit	
Press [ENTER]		ARC Limit = Disable 0-40mA 0 = Disable
Select ARC Limit (mA)	Press Numerical & Decimal keys to enter ARC limit	
Press [ENTER]		Test Time = _10.0s 0-999 s 0 = Disable
Select Test Time (sec)	Press Numerical & Decimal keys to enter Test Time	
Press [ENTER]		Ramp Time = Disable 0-999 s 0 = Disable
Select Ramp Time (sec)	Press Numerical & Decimal keys to enter Ramp Time	
Press [ENTER]		Select Step = 1 1-10 (UP/DOWN)
Press [PROG]		Step-01 10.0s 1.200KV WAC 0.500mA

* **Applicable only if internal/external scanner installed. Reference ¶ 2.2 and 3.3**

2.3.2 Programming a DC Hipot Test

Press [PROG]		Select Step = 1 1-10 (UP/DOWN)
Select Test Step	Press UP or DOWN arrow key to enter test step	
Press [ENTER]		Select Mode = WDC Press UP/DOWN
Select Test MODE	Press UP arrow key to display WDC	
Press [ENTER]		High =Disable Scan Box-Channel 1
Select Scanner Disable*	Press Numerical keys to enter high scanner channels	
Press [ENTER]		Low = Disable Scan Box-Channel 1
Select Scanner Disable*	Press Numerical keys to enter low scanner channels	
Press [ENTER]		Voltage = 0.000KV 0.05-6KV
Select Test Voltage (KV)	Press Numerical & Decimal keys to enter test voltage	
Press [ENTER]		High Limit = 0.500mA 0.0001-20mA
Select High Limit (mA)	Press Numerical & Decimal keys to enter high current limit	
Press [ENTER]		Low Limit = Disable 0-20mA 0 = Disable
Select Low Limit (mA)	Press Numerical & Decimal keys to enter low current limit	
Press [ENTER]		ARC Limit = Disable 0-20mA 0 = Disable
Select ARC Limit (mA)	Press Numerical & Decimal keys to enter ARC limit	
Press [ENTER]		Test Time = _10.0s 0-999 s 0 = Disable
Select Test Time (sec)	Press Numerical & Decimal keys to enter Test Time	
Press [ENTER]		Ramp Time = Disable 0-999 s 0 = Disable
Select Ramp Time (sec)	Press Numerical & Decimal keys to enter Ramp Time	
Press [ENTER]		Select Step = 2 1-10 (UP/DOWN)
Press [PROG]		Step-01 10.0s 1.200KV WDC 0.500mA

* Applicable only if internal/external scanner installed. Reference ¶ 2.2 and 3.3

2.4 Programming an Insulation Resistance Test

Press [PROG]		Select Step = 1 1-10 (UP/DOWN)
Select Test Step	Press UP or DOWN arrow key to enter test step	
Press [ENTER]		Select Mode = IR Press UP/DOWN
Select Test MODE	Press UP arrow key to display IR	
Press [ENTER]		High =Disable Scan Box-Channel 1
Select Scanner Disable*	Press Numerical keys to enter high scanner channels	
Press [ENTER]		Low = Disable Scan Box-Channel 1
Select Scanner Disable*	Press Numerical key to enter low scanner channels	
Press [ENTER]		Voltage = 0.000KV 0.05-1 KV
Select Test Voltage (KV)	Press Numerical & Decimal keys to enter test voltage	
Press [ENTER]		Low Limit = _ 1.0MΩ 0.1-50000 MΩ
Select Low Limit (MΩ)	Press Numerical & Decimal keys to enter low resistance limit	
Press [ENTER]		High Limit = Disable 0-5000 MΩ 0 = Disable
Select High Limit (MΩ)	Press Numerical & Decimal keys to enter high resistance limit	
Press [ENTER]		Test Time = _10.0s 0-999 s 0 = Disable
Select Test Time (sec)	Press Numerical & Decimal keys to enter Test Time	
		Ramp Time = Disable 0-999 s 0 = Disable
Select Ramp Time (sec)	Press Numerical & Decimal keys to enter Ramp Time	
Press [ENTER]		Select Step = 1 1-10 (UP/DOWN)
Press [PROG]		Step-01 10.0s 1.200KV IR 0.500mA

* Applicable only if internal/external scanner installed. Reference ¶ 2.2 and 3.3

2.5 Programming a Ground Bond Test

Press [PROG]

Select Step = 1
1-10 (UP/DOWN)

Select Test Step

Press UP or DOWN arrow key to enter test step

Press [ENTER]

Select Mode = GR
Press UP/DOWN

Select Test MODE

Press UP arrow key to display GR

Press [ENTER]

High = Disable
Scan Box – 1 Channel

Select Scanner Disable*

Press Numerical keys to enter high scanner channels

Press [ENTER]

Current = _0.00A
1-30A

Select Current

Press Numerical keys to enter current in (A)

Press [ENTER]

High Limit = 100.0mΩ
0.1-510mΩ

Select High Limit (mΩ)

Press Numerical /Decimal keys to enter high limit in (mΩ)

Press [ENTER]

Low Limit = Disable
0.1-510mΩ 0=Disable

Select Low Limit (mΩ)

Press Numerical /Decimal keys to enter low limit in (mΩ)

Press [ENTER]

Test Time = _10.0s
0-999s 0=Disable

Select Test Time (sec)

Press Numerical & Decimal keys to enter test time in (sec)

Press [ENTER]

Select Step = 1
1-10 (UP/DOWN)

Press [PROG]

Step-01 10.0s
1.00A GR 100.0mΩ

* Applicable only if internal/external scanner installed. Reference ¶ 2.2 and 3.3

2.6 Programming a Leakage Current Test

2.6.1 Simulated Leakage Current

Press [PROG]

Select Step = 1
1-10 (UP/DOWN)

Select Test Step Press UP or DOWN arrow key to enter test step

Press [ENTER]

Select Mode = LC
Press UP/DOWN

Select Test MODE Press UP arrow key to display LC

Press [ENTER]

High = Disable
Scan Box – 1 Channel

Select Scanner Disable*Press Numerical keys to enter high scanner channels

Press [ENTER]

Low = Disable
Scan Box – 1 Channel

Select Scanner Disable*Press Numerical keys to enter high scanner channels

Press [ENTER]

Voltage = _0.000kV
0.05 – 0.4kV

Select Voltage Press Numerical keys to enter voltage in (kV)

Press [ENTER]

High Limit = 6.000mA
0.001 – 9.999mA

Select High Limit (mA) Press Numerical & Decimal keys to enter high limit in (mA)

Press [ENTER]

Low Limit = Disable
0 – 9.999mA 0=Disable

Select Low Limit (mA) Press Numerical & Decimal keys to enter low limit in (mA)

Press [ENTER]

Test Time = Disable
0-999s 0=Disable

Select Test Time (sec) Press Numerical & Decimal keys to enter Test Time in (sec)

Press [ENTER]

Ramp Time = Disable
0-999s 0=Disable

Select Ramp Time (sec) Press Numerical & Decimal keys to enter RampTime in (sec)

Press [PROG]

Select Step = 1
1-10 (UP/DOWN)

Step-01 0.0s
0.000kV LC 6.000mA

*** Applicable only if internal/external scanner installed. Reference ¶ 2.2 and 3.3**

2.6.2 True Line Leakage Current (6000-04 installed)

If the Guardian 6000-04 Scanner is installed on the rear panel of the Guardian 6000 unit, then the instrument will measure the ‘true’ Earth/Line leakage of the DUT. The word ‘true’ is used to distinguish this test from the simulated line leakage described in paragraph 2.6.1. Other terminology used to describe ‘true’ line leakage is ‘dynamic’ or ‘real’ line leakage. The 6000-04 scanner requires the use of an isolation transformer for proper operation. For a ‘true’ line leakage test, connect the DUT to the Guardian 6000 rear panel output terminals as shown in Figure 2-2. Please refer to QuadTech Instruction Manual 150528 for more detailed information on the 6000-04 line leakage scanner.

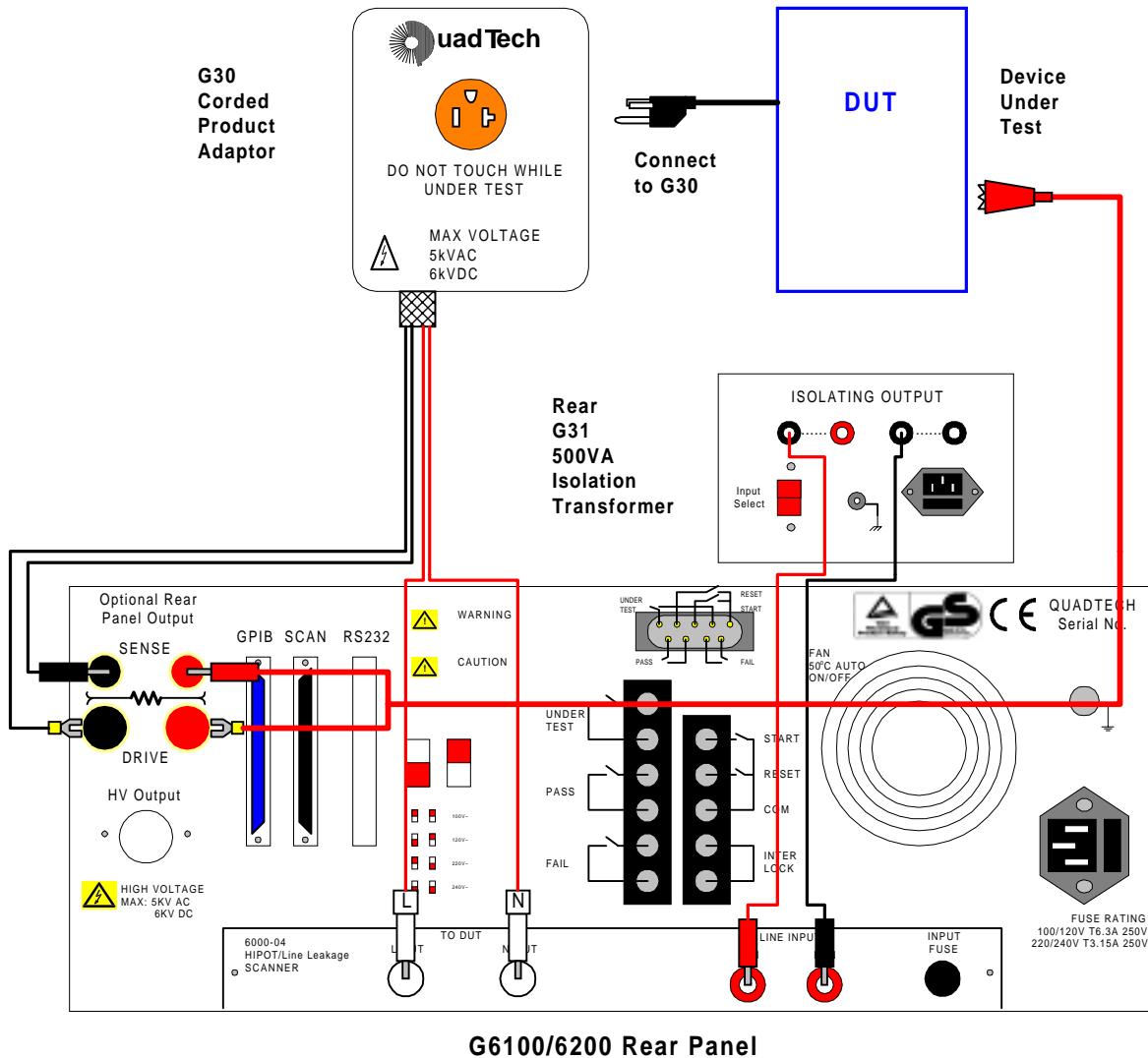

Figure 2-2: Connection of DUT to 6000-04 for Line Leakage Test

LC Programming Instructions: For use when 6000-04 Scanner is installed in G6000.

Press [BUTTON]:

Display Reads:

[PROG]

Select Step = 1 1 - 10 (UP/DOWN)

Select Test Step

Press UP or DOWN arrow key to enter test step

[ENTER]

Select Mode = LC Press (UP/DOWN)

Select Test Mode

Press UP arrow key to display LC

[ENTER]

Device = D1 UL544NP Select by UP/DOWN
--

Select Device (Human Circuit Model)

Press UP arrow key to display model #

[ENTER]

Line = LO NORMAL Select by UP/DOWN

Select Line (Fault Simulation)

Press UP arrow key to display line (Normal, Reverse, Single Fault Normal, Single Fault Reverse)

[ENTER]

High Limit = 6.000 mA 0.001 - 9.999 mA

Select High Limit

Press Numerical & Decimal keys to enter high current limit

[ENTER]

Low Limit = Disable 0 - 9.999 mA 0 = Disable

Select Low Limit

Press Numerical & Decimal keys to enter low current limit

[ENTER]

POWER = VOLTAGE Select by Up/DOWN

Select Power (DUT Power Monitor)

Press UP arrow key to display power mode (V, A or VA)

[ENTER]

VA High = Disable 0 - 2200 VA 0=Disable
--

Select High Limit

Press Numerical & Decimal keys to enter high power limit

[ENTER]

VA Low = Disable 0 - 2200 VA 0 = Disable

Select Low Limit

Press Numerical & Decimal keys to enter low power limit

[ENTER]

Test Time = 3.0 s 0 - 999 s 0 = Disable
--

Select Test Time

Press Numerical & Decimal keys to enter test time

[ENTER] [PROG]

STEP - 01 D1 L0 3.0 s Disable LC 6.000 mA
--

2.7 Programming A Multi-Step Test

Each test can consist of 1 to 10 steps in sequence, for example, a typical three step test might be an AC hipot test followed by an IR test and followed by a Ground Continuity test. Each step may be programmed for any available function (ACV, DCV, IR or GR for ground bond) with programmed test conditions independent from the other step.

To change the test mode proceed as follows:

- Press [**STOP**]

Step-01	1.0s
1.200KV WAC	7.50mA

- Press [**UP**] arrow
To select/examine steps 2-10

Step-02	1.0s
1.500KV WDC	15.00mA

Step-03	1.0s
0.750KV IR	1.0MΩ

Step-04	1.0s
20.00A GR	

- Press [**DOWN**] arrow
To return to lower steps.

Step-01	1.0s
1.200KV WAC	7.50mA

- **NOTE for a SINGLE STEP TEST**

The test voltage (or current for a ground bond test) for Step 2 must be set to 0.00. Likewise, for a TWO STEP test the voltage or current for Step 3 must be set to 0.00.

- To change a test mode select the step to be changed (1 to 10) as described above.

- Press [**PROG**]

Select Step = 1
1-10 (UP/DOWN)

- Press [**UP**] arrow key
To select step to be changed

Step-01	1.0s
1.200KV WAC	

- Press [**ENTER**]

Select Mode = WAC
Press UP/DOWN

- REPROGRAM per paragraphs 2.3.1 (AC Hipot), 2.3.2 (DC Hipot), 2.4 (IR) 2.5 (Ground Bond) and 2.6 (Leakage Current).

2.8 Storing a Test Setup

2.8.1 Storing a Single Step Test

To store a single test setup, program the test in accordance with your test specification and paragraphs 2.3.1, 2.3.2, 2.4, 2.5 or 2.6 of this manual. Follow the procedure illustrated below.

Press **[Sto]**

Store Memory : _1 1

Enter storage location for test setup

Store Memory : 12 -

Press **[ENTER]**

Enter additional numeric name for memory location (If desired). Otherwise press ENTER.

Store Memory : 12 Store ?

Press **[ENTER]**

Step-01	1.0s
1.200KV WAC	7.50mA

2.8.2 Storing a Multi-Step Test

To store a multi-step test, program the tests in accordance with your test specification and paragraphs 2.3.1, 2.3.2, 2.4, 2.5, 2.6 and 2.7 of this manual. An example of an AC/IR/GR test sequence is illustrated below.

Press **[PROG]**

Select Step 01

Press **[ENTER]**

AC Test per ¶ 2.3.1

*

*

*

continue entering AC test setup

After entering RAMP Time, display reads Select Step = 2

Select Step 02

Press **[ENTER]**

IR Test per ¶ 2.4

*

*

*

continue entering IR test setup

After entering RAMP Time, Select Step = 3

Select Step 03

Press **[ENTER]**

GR Test per ¶ 2.5

*

*

*

continue entering GR test setup

After entering TEST Time, Press **[PROG]**

Press **[Sto]**

Store Memory : _1
1

Enter storage location

Store Memory : _ 3

Press **[ENTER]**

Store Memory : 3
—

Press **[ENTER]**

Store Memory : 3
Store ?

Press **[ENTER]**

Step – 01 1.0s
1.200KV WAC 7.50mA

To verify the storage, press **[Rcl]** once. Enter the storage location. Press **[ENTER]** three times. Use **[UP]** arrow key to view Steps 02 and 03. Use **DOWN** arrow key to return to Step 01.

2.9 Instrument Zeroing/Offset

The Guardian 6000 provides automatic zeroing/offset for lead or fixture effects. During the zeroing/offset process a correction is made (subtracted out) as the result of lead leakage current and stored in instrument memory to be applied to ongoing measurements. For maximum measurement accuracy it is recommended that the unit be zeroed after power-up, any time the test parameters are changed and any time the test leads or fixture are changed. The offset is saved under setup storage (1 - 50 setups) and is also saved on a power down and power back up. **The instrument should warm-up for at least 15 minutes before zeroing. Test parameters should be programmed and test cables connected prior to initializing the offset function. Refer to ¶ 2.10 for the correct cable connection.**

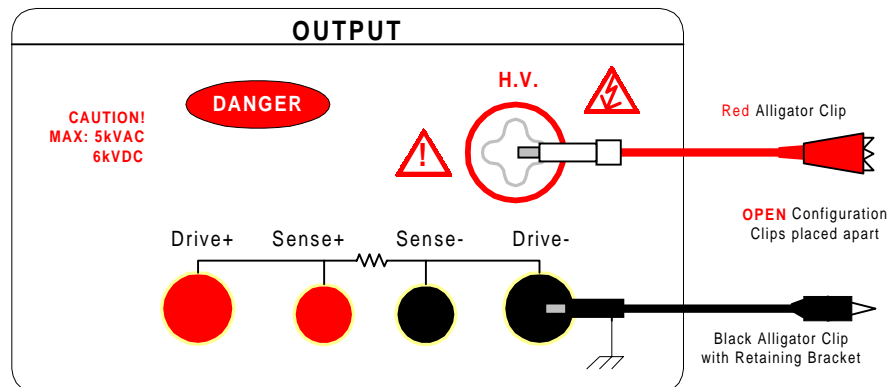

Figure 2-3: Zero/Offset OPEN Configuration

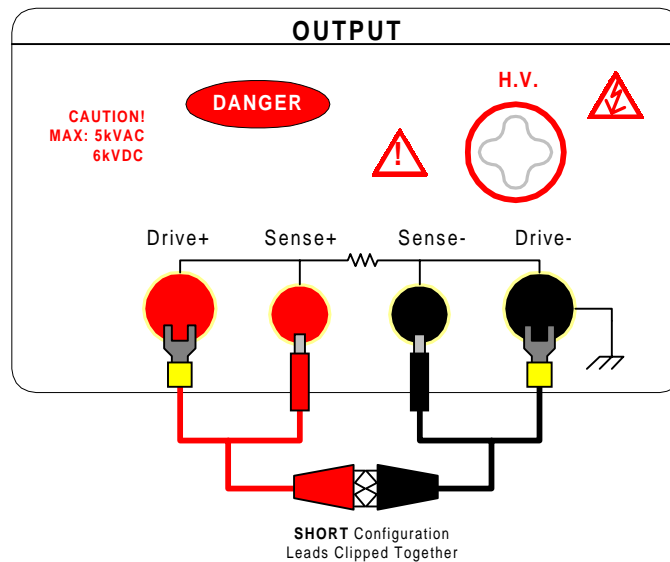

Figure 2-4 : Zero/Offset SHORT Configuration

Proceed as follows for automatic zeroing/offset:

- Plug the appropriate cable (or other fixture) into the front panel OUTPUT connectors, **with no device connected**. Refer to paragraph 2.10 for cable configurations based on test to be made. **NOTE:** Test leads for AC Hipot, DC Hipot and IR measurements should be OPEN and test leads for GR should be SHORTED before performing the OFFSET function.
- Press the [OFFSET] key.

Offset is GET Press Test Key.

- Press the green [TEST] button.
Green Offset LED is lit

Step-01 Pass 0.0s 1.200KV WAC

- Press the [OFFSET] key.
Green Offset LED is lit

Offset is ON Press the Offset Key.

- Press the [OFFSET] key once.

Offset is OFF Press the Offset Key.
--
- Press the [ENTER] key to accept
OFFSET ON or OFF

Step-01 1.0s 1.200KV WAC 7.50mA
--

The following formulas apply to the offset function:

For AC offset current < 80μA:

$$\text{Display current} = \sqrt{(\text{current read})^2 - (\text{offset current})^2}$$

For DC offset or AC offset current ≥ 80μA:

$$\text{Display current} = (\text{current read}) - (\text{offset current})$$

2.10 Connection to Device Under Test

Before connecting the device for test, press the red [STOP] key and make sure the red **DANGER** light is **OFF**.

Depending on the test to be conducted (Hipot, IR or Ground Bond) connect the test cables to the front panel OUTPUT connectors. Refer to the Figures 2-5 through 2-9 to determine the correct configuration. When using the black cable, with the metal retaining bracket, make sure it is locked behind the connector to prevent this cable from accidentally coming loose.

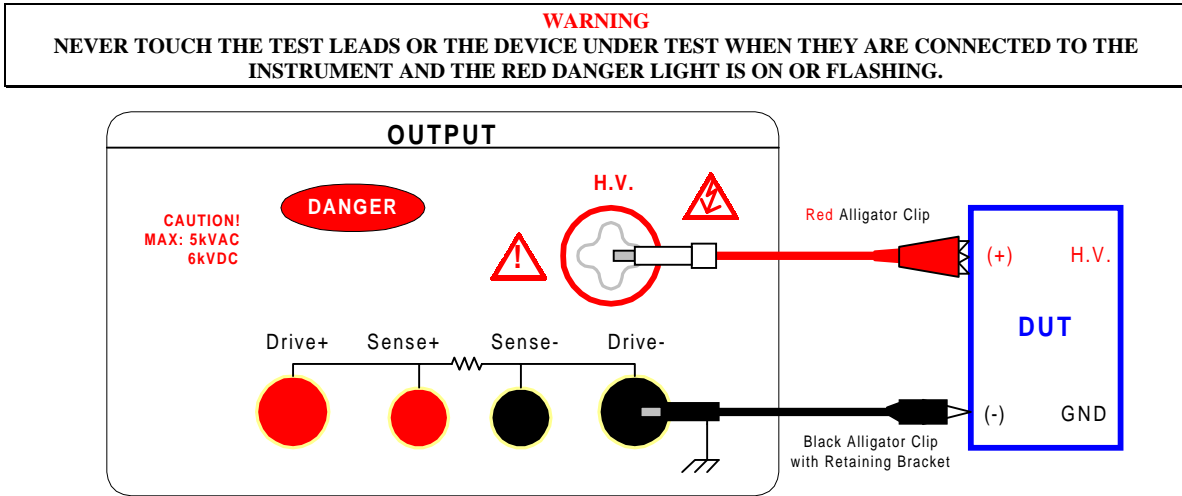

Figure 2-5: Connection for Hipot/IR Test (Using S02 Cable Lead Set)

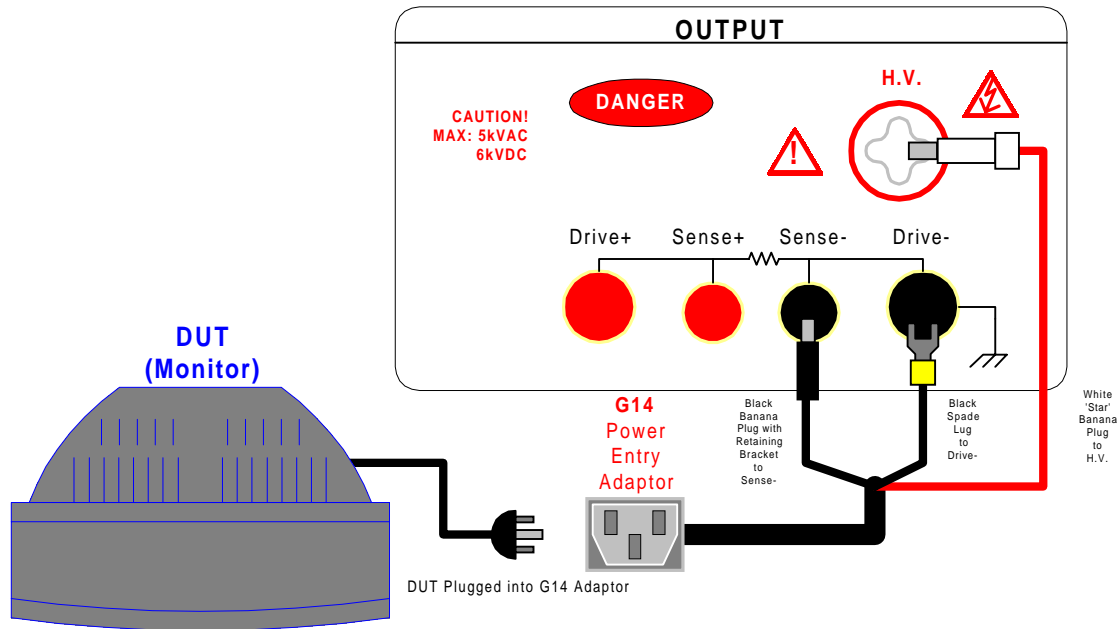

Figure 2-6: Connection for Hipot Test (Using G14 Power Entry Cable)

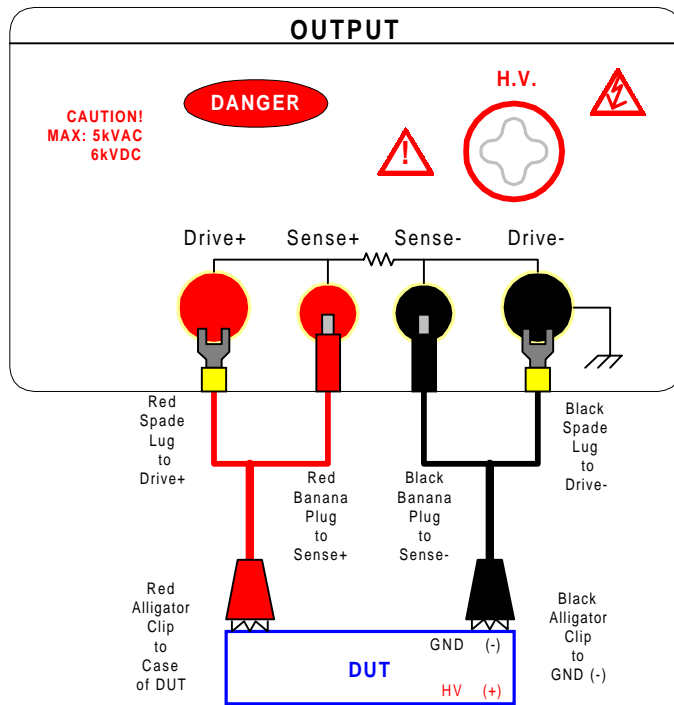

Figure 2-7: Connection for Ground Continuity Test (Using G15 Cable Lead Set)

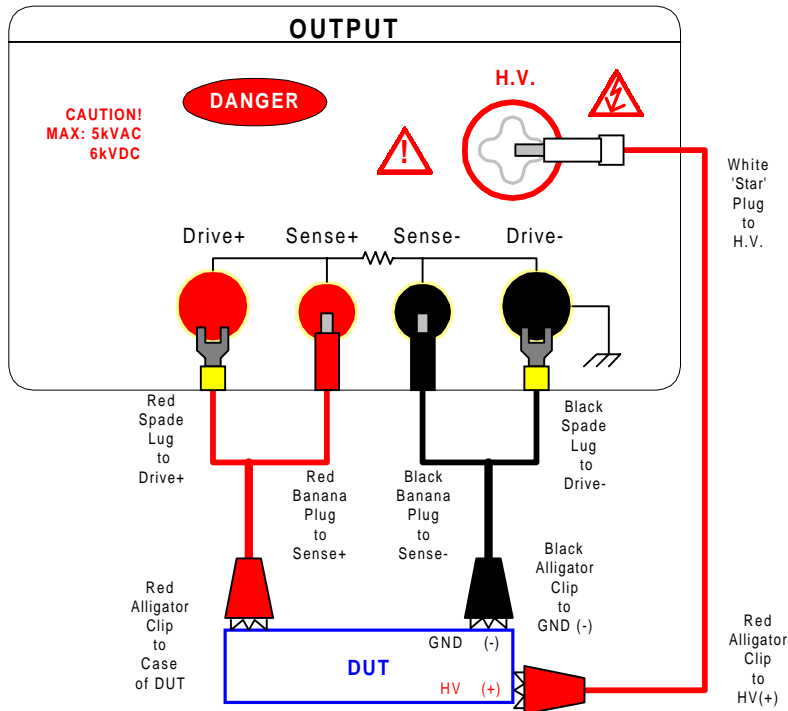

Figure 2-8: Connection for Hipot and GC Test (Using S02 & G15 Lead Sets)

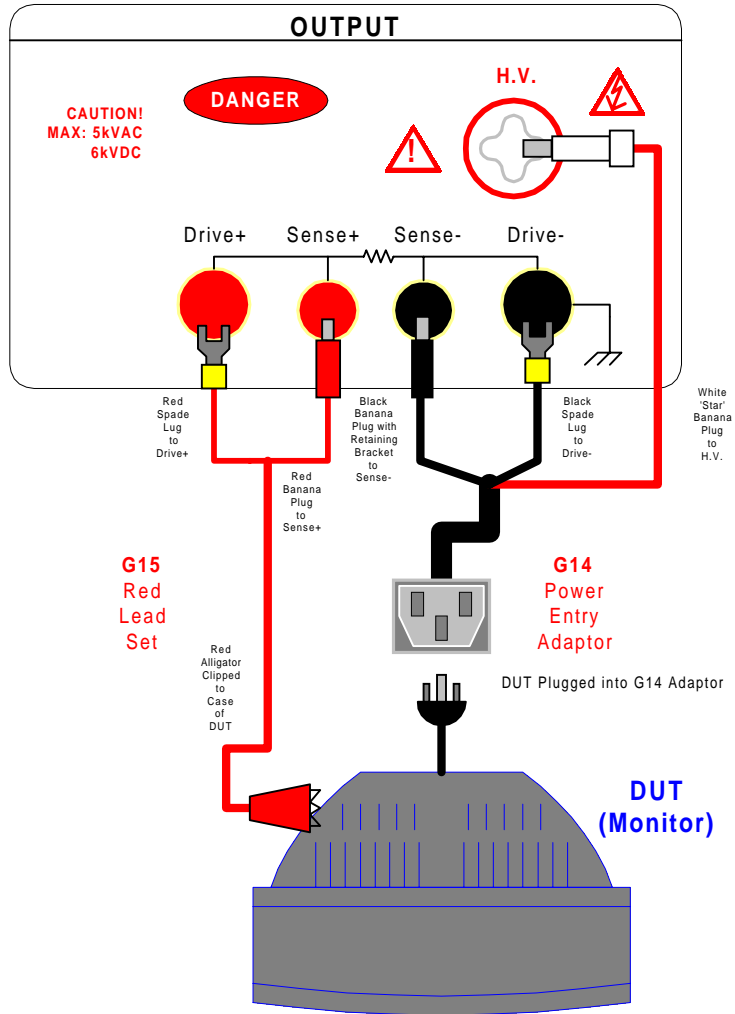

Figure 2-9: Connection for Hipot and GC Test (Using G15 (red only) & G14 Cables)

2.11 Measurement Procedure

Before a measurement is made, verify the following:

- 1 Guardian 6000 unit power is ON
- 2 15 minute warm-up
- 3 Test parameters programmed
- 4 Test Setup stored
- 5 Offset function selected
- 6 Device Under Test (DUT) connected

The operator has a choice of performing a test at power-up conditions (test conditions at which the instrument was last powered down), or recalling one of 50 possible stored setups. Refer to paragraphs 2.3, 2.4, 2.5, 2.6, 2.7 or 2.8 for instructions to change the test mode and/or test conditions.

To initiate a test at “power-up conditions” proceed as follows:

- Press **[STOP]**
Green Offset LED is lit

Step-01	1.0s
1.200KV WAC	7.50mA

- Press **[START]**
Danger LED flashes, Offset LED is lit
Green PASS LED is lit

Step- 01 Pass	0.0s
1.200KV WAC	

- Press **[STOP]**
Any time to stop test
Green Offset LED is lit

Step-01	1.0s
1.200KV WAC	7.50mA

To RECALL one of the 50 setups proceed as follows:

- Press the **[RCL]** key.

Recall Memory : _1
1

- Enter storage number of test setup
Press **[ENTER]**

Recall Memory : _2

- Press **[ENTER]**

Recall Memory : 2
Recall?

- Press **[ENTER]**

Step-01	1.0s
1.200KV WAC	7.50mA

2.12 Initial Parameter Settings

The Guardian 6000 has a number of parameter settings that seldom require change, the instrument will power-up with default settings. Each of these parameters are listed in the Table 2-2 and can be changed using the following procedure.

Table 2-2: Initial Parameter Setting

Display		Range	Default Value
A General Setting			
	Contrast	1-15	6
	Beep Vol.	ON : 1,2,3 / OFF	3
	Scan No.	1-8	1
	Fail Retest	ON/OFF	OFF
	Print Pass	ON/OFF	OFF
	Print Fail	ON/OFF	OFF
	Timer U/D	UP/DOWN	DOWN
B Timing Setting			
	Pass Hold	0.2-99.9s	0.5
	Step Hold	ON : 0, 0.1-99.9s	0.2
	Judg. Wait	0.1-1.0s	0.3
	DC Wait	0.0-99.9s	0.0
C Special Setting			
	AC-V Freq.	50-600 Hz	60
	G-R Freq.	50-60 Hz	60
	G-R Voltage	6.0-15.0 V	15.0
	Auto Range	ON/OFF	OFF
	Soft. AGC	ON/OFF	ON
	Password	ON/OFF	OFF
	G-R Cont.	ON/OFF	OFF
	Simulation	n _{CORRECTION} : ±(5-50%) or OFF	OFF
	IEC601-1	ON/OFF	OFF
	Lock Rcl	ON/OFF	OFF
D Remote Setting			
	GPIB Addr.	1-31	3
	Baud Rate	0.3, 1.2, 2.4, 4.8, 9.6, 19.2 kbps	9.6
	GPIB Comp.	ON/OFF	OFF

To select initial parameter setting mode:

Press **ENTER** and then [6] [0] [0] [0].

A. General Setting

Press → (Press numerical keys & ENTER)

1. Contrast = _ 4
1-15

Press ↑ (Press OFF Key & ENTER)

2. Beep Vol. = OFF
Off /1/2/3 (OFF Key)

Press ↑ (Press numerical keys & ENTER)

3. Scan NO. = _ 1
1-8

Press ↑ (Press OFF Key & ENTER)

4. Fail Retest = OFF
On/Off (OFF Key)

Press ↑ (Press OFF Key & ENTER)

5. Print PASS = OFF
On/Off (OFF Key)

Press ↑ (Press OFF Key & ENTER)

6. Print FAIL = OFF
On/Off (OFF Key)

Press ↑ (Press OFF Key & ENTER)

7. Timer U/D = DOWN
Up/Down (OFF Key)

Press ←

A. General Setting

Press ↑

B. Timing Setting

Press → (Press numerical keys & ENTER)

1. Pass Hold = _ 1.0s
0.2 - 99.9s

Press ↑ (Press numerical keys & ENTER)

2. Step Hold = _ 1.0s
On, 0.1 - 99.9s

Press ↑ (Press numerical keys & ENTER)

3. Judg. Wait = _ 0.1s
0.1 - 99.9s

Press ↑ (Press numerical keys & ENTER)

4. DC Wait = _ 0.0s
0.0 - 99.9s

Press ←	B. Timing Setting
Press ↑	C. Special Setting
Press → (Press numerical keys & ENTER)	1. AC-V Freq. = _ 60Hz 50 - 600 Hz
Press ↑ (Press numerical keys & ENTER)	2. G-R Freq. = _ 60Hz 50 - 60 Hz
Press ↑ (Press numerical keys & ENTER)	3. G-R Volt. = <u>15.0</u> V 6.0 - 15.0 V
Press ↑ (Press OFF Key & ENTER)	4. Auto Range = ON On/Off (OFF Key)
Press ↑ (Press OFF Key & ENTER)	5. Soft. AGC = ON On/Off (OFF Key)
Press ↑ (Press OFF Key & ENTER)	6. Password = OFF On/Off (OFF Key)
Press ↑ (Press OFF Key & ENTER)	7. G-R Cont. = OFF On/Off (OFF Key)
Press ↑ (Press OFF Key & ENTER)	8. Simulation = OFF 5.0 - 50.0%
Press ↑ (Press OFF Key & ENTER)	8. IEC601-1 = OFF On/Off (OFF Key)
Press ↑ (Press OFF Key & ENTER)	10. Lock Rcl = OFF On/Off (OFF Key)
Press ←	C. Special Setting

Press ↑

D. Remote Setting

Press → (Press numerical keys & ENTER)

1. GPIB Addr. = _ 3
1 - 31

Press ↑ (Press numerical keys & ENTER)

2. Baud Rate = 9600
0.3 - 19.2 (OFF Key)

Press ↑ (Press OFF Key & ENTER)

3. GPIB Comp. = OFF
On/Off (OFF Key)

Shown above is the entire scroll through the initial parameter settings. The parameters can be changed singularly. To exit Initial Parameter Setting mode, press [PROG]. The display will return to test set-up.

2.12.1 General Settings

In Initial Parameter Setting mode, the Guardian 6000 unit has seven programmable parameters listed under “A. General Setting”. These parameters are Contrast, Beep Vol., Scan No., Fail Retest, Print Pass, Print Fail and Timer U/D.

2.12.1.1 Contrast

The Contrast of the display is adjustable from 1 – 15. A value of 1 is brightest, a value of 15 is darkest. The default setting for Contrast is 6.

NOTE

Contrast can be adjusted at any time the unit is powered up by pressing the left/right arrow key.

If display is totally blank, press the right arrow key to bring the Contrast back.

2.12.1.2 Beep Volume

The volume of the buzzer has four levels of adjustment : OFF, 1, 2 & 3. When OFF is selected the buzzer will not sound. When [1] is selected the buzzer emits a low volume sound. [2] corresponds to a mid level volume and [3] corresponds to a high level volume. The Beep Vol. default value is 3.

2.12.1.3 Scan Number

The Scan No. setting allows the option of selecting which scan box is being used. The range is 1 – 8 and the default value is 1 (Internal Scanner if one is installed).

2.12.1.4 Fail Retest

The Fail Retest setting allows the option of automatic retest of a device upon fail. The programmable setting is ON or OFF and the default setting is OFF.

2.12.1.5 Print PASS

The Print Pass function of the Guardian 6000 unit is used in conjunction with the printer interface. The instrument default value is OFF. When Print Pass is selected ON, the test data will be printed out when a PASS occurs.

2.12.1.6 Print FAIL

The Print Fail function of the Guardian 6000 unit is used in conjunction with the printer interface. The instrument default value is OFF. When Print Fail is selected ON, the test data will be printed out when a FAIL occurs.

2.12.1.7 Timer U/D

Timer U/D controls/changes whether the test time counts down or counts up. The range for Timer U/D is Up or Down and the default value is Down.

2.12.2 Timing Settings

In Initial Parameter Setting mode, the Guardian 6000 has four programmable parameters listed under “B. Timing Setting”. These parameters are Pass Hold, Step Hold, Judg. Wait and DC Wait.

2.12.2.1 Pass Hold

The Pass Hold setting allows the option of programming a hold time on a multiple step test. The range for Pass Hold is 0.2 – 99.9 sec and the default value is 0.5sec.

2.12.2.2 Step Hold

The Step Hold setting allows the option of programming a hold time on a single step test. The range for Step Hold is ON, 0.1 – 99.9sec. and the default value is 0.2sec. When Step Hold is ON, the test will stop after one step and display PASS/FAIL

2.12.2.3 Judgement Wait

The Judg. Wait setting allows the option of programming a hold time on a single step test. This allows the device to be fully charged prior to a measurement being made and then judged PASS/FAIL. The range for Judg. Wait is 0.1 – 99.9sec and the default value is 0.3sec.

2.12.2.4 DC Wait

DC Wait is for a fixed discharge time after the measurement for DC HIPOT ONLY. The range for DC Wait Time is adjustable from 0.0 to 99.9s and the default value is 0.0s.

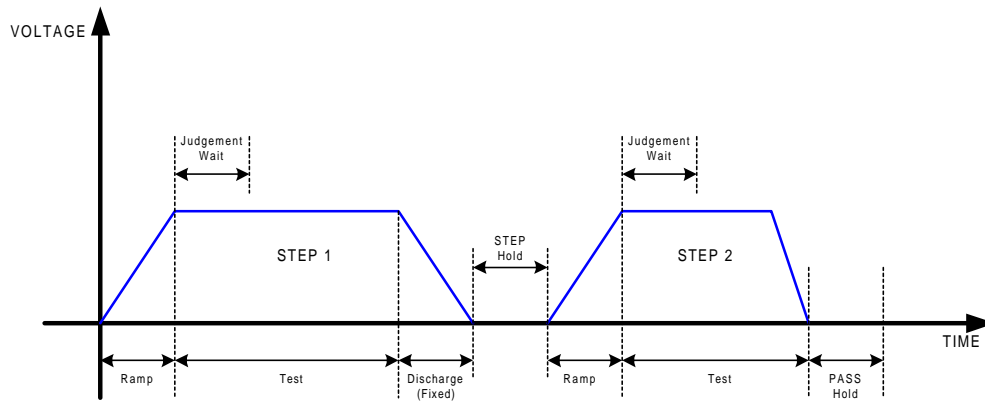

Figure 2-10: Timing Diagram G6000 Hold Settings

2.12.3 Special Settings

In Initial Parameter Setting mode, the Guardian 6000 has ten programmable parameters listed under “C. Special Setting”. These parameters are AC-V Freq., G-R Freq., G-R Volt, Auto Range, Soft. AGC, G-R Cont., Password, Simulation, IEC601-1 and Lock Rcl.

2.12.3.1 AC-V Freq.

The AC V Freq. setting allows the option of programming the frequency for the AC hipot test. The range of AC-V Freq. is 50 – 600Hz and the default value is 60Hz.

2.12.3.2 G-R Freq.

The G-R Freq. setting allows the option of programming the frequency for the Ground Bond (GR) test. The range of G-R Freq. is 50 – 60 Hz and the default value is 60Hz.

2.12.3.3 G-R Volt

The G-R Volt setting allows the option of programming the voltage for the Ground Bond (GR) test. The range of G-R Volt is 6.0 – 15.0V and the default value is 15.0V.

2.12.3.4 Auto Range

The Auto Range setting allows the option of using the full scale current range (ON) or using the user programmed maximum current limit (OFF). The low current range (3mA full scale) results in increased measurement resolution. The default value of Auto Range is OFF.

2.12.3.5 Software AGC

The Software Automatic Gain Control setting allows the option of correcting the output voltage (Soft. AGC = ON). This is okay when measuring resistors but under special circumstances when measuring large capacitive devices it is best to select Soft. AGC OFF. The instrument default value is ON.

2.12.3.6 Password

The G6000 unit is shipped with the default password set to [6][0][0][0]. This password can be changed. Press [ENTER] [6][0][0][0] to select System Settings. Select [C. Special Settings]. Select [6. Password] = [ON]. Enter a new password up to 8 digits using the numerical keys [0] through [9]. When a password is entered, the G6000 comes back with “CHK : _” and the password needs to be entered a second time to confirm. Pressing the [Dele] key at this time will clear the password just entered. This password will also change the password for front panel lockout. To override a password press [ENTER] [8][5][2][4][6][3][1][7][9] [ENTER]. The display will then show the current password. Return to System (Special) Settings to disable the password function. Figure 2-9 illustrates the password setting function.

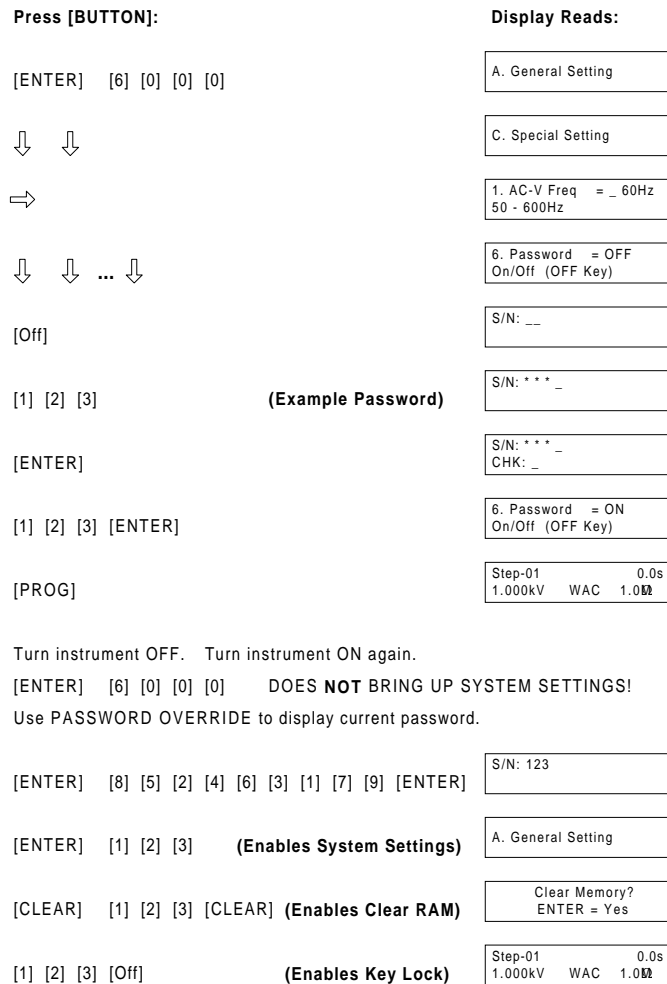

Figure 2-11: Setting a Password

2.12.3.7 G-R Cont.

The Ground Resistance Continue-on-Fail function of the Guardian 6000 can be selected ON or OFF. The instrument default value is OFF. When G-R Cont. is selected ON, the unit will continuously operate in GR mode and will not stop the measurement if a failure occurs. The Pass/Fail and output relay operate normally. The buzzer will continuously sound if a failure occurred during the test. This function allows manual probing of continuity on a product.

2.12.3.8 Simulation

In simulated line leakage mode a correction (% value) can be added to better simulate what the true line leakage would be. This parameter has no effect on “True Line Leakage Measurement” (§2.6.2). The simulation correction value can be programmed in whole number increments of \pm (5-50%).

2.12.3.9 IEC601-1

The IEC601-1 feature is applicable to (WDC) DC hipot only. This test is basically Insulation Breakdown per IEC601-1, Clause 20. The G6000 unit will initially apply $\frac{1}{2}$ the programmed test voltage, then gradually apply a linear ramp to the test voltage over the programmed ramp time until the required test voltage is achieved. The G6000 holds the voltage for the programmed test time then ramps back down identical to the ramp up.

2.12.3.10 Lock Rcl

“Lock Rcl” is used to lockout the ability to recall stored information. The range for Lock Rcl is ON or OFF and the default value is OFF. When the front panel is locked using the “Key Lock” function (§2.13) memory locations may or may not be recalled. If Lock Rcl is ON, memory locations can not be recalled when “Key Lock” is ON. When Lock Rcl is OFF, memory locations can be recalled.

2.12.4 Remote Settings

In Initial Parameter Setting Mode, the Guardian 6000 has three programmable parameters listed under “D. Remote Setting”. These parameters are GPIB Addr., Baud Rate, and GPIB Comp.

2.12.4.1 GPIB Address

The GPIB Addr. setting allows the option of programming the GPIB (IEEE-488) address. The range is 1 – 31 and the instrument default value is 3.

2.12.4.2 Baud Rate

The Baud Rate setting allows the option of selecting the Baud Rate in kbps. The range is 0.3, 1.2, 2.4, 4.8, 9.6, and 19.2 kbps. The instrument default value is 9.6 kbps.

2.12.4.3 GPIB Comp.

“GPIB Comp” is the compatibility function of the G6000 unit. “GPIB Comp” can be selected ON or OFF. The instrument default value is OFF. When selected ON the Guardian 6000 GPIB data output is compatible with the Guardian 5000 GPIB data output.

2.13 Front Panel Lockout

With front panel lock in effect the ability to change test conditions is prohibited. Only the [TEST] and [STOP] buttons and the setup recall function (RCL) are functional.

To activate the front panel lockout:

- With the instrument in standby status (Stop button previously pressed and no lights flashing) enter [6] [0] [0] [0] and [OFF] from the data entry keys. The green KEY LOCK indicator light will illuminate indicating the instrument is in the lockout state. The display shows the test set-up.

To deactivate the front panel lockout:

- With the instrument in standby status (Stop button previously pressed and no lights flashing) enter [6] [0] [0] [0] and [OFF] from the data entry keys. The green KEY LOCK indicator light will go out indicating the instrument is no longer in the lockout state. The display shows the test set-up.

NOTE

Code for lockout will change if password has been entered (¶ 2.12.3.6)

2.14 Software Version Display

The version of software, installed in the instrument, can be displayed on the front panel.

To display software version:

- Press [POWER] switch to ON (1) and immediately press the [ENTER] key.

Guardian 6000 Date : 08/18/2000

GPIB Address : 03 Baud Rate : 9600

- The display is held for just a few seconds and then reverts to the test set-up display.

2.15 Clear Setup Memory

All stored test conditions in instrument memory (50 setups) can be cleared with a few key strokes.

To clear setup memory:

- With the instrument in standby status (Stop button previously pressed and no lights blinking) press [CLEAR] and then [6] [0] [0] [0] and [CLEAR] again.

Clear Memory ?
ENTER = Yes

- Press [ENTER]

Guardian 6000
Date : 08/18/2000

GPIB Address : 03
 Baud Rate : 9600

- The Beeper sounds loud (to alert that memory has been cleared) and all LED's flash once. The display is held for just a few seconds and then reverts to the test set-up display.
- The Beeper will remain ON until it is turned OFF by entering Initial Parameter Setting mode [ENTER 6000], selecting [A. General Setting], [2. Beep Vol. = OFF] and pressing [ENTER]. Remember to press [PROG] to exit Initial Parameter Setting and return to test set-up display.

Section 3 : Interface

3.1 Remote

A 9 pin D-series remote control connector is located on the rear panel of the G6000 instrument. There is a black 6 screw relay strip for the remote output signals : UNDER TEST, PASS & FAIL. There is a black 5 screw relay strip for the remote input connections : START, RESET, COM & INTER LOCK.

Inputs require a contact closure and outputs provide a contact closure, as shown in Figure 3-1.

Before connecting the instrument to its power source the **interlock function** on the rear panel remote connector must be properly utilized. **This is an important safety feature for the protection of the operator.** Turn on of the instrument's high voltage is inhibited with no interlock connection and is functional with the interlock jumper in place (as shipped from the factory).

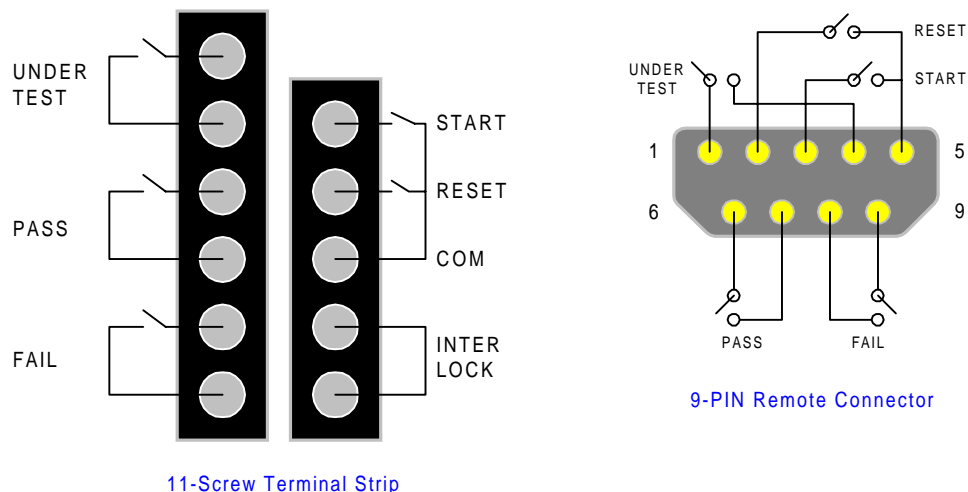

Figure 3-1: Remote Control Connections

The G6000 unit has three output signals on the rear panel. The UNDER TEST output terminal is short during TEST as the relay contacts connect to the device powered by 115VAC and current < 0.3A. The PASS output terminal is short when DUT is judged GOOD. The FAIL output terminal is short when DUT is judged NO-GOOD.

Figures 3-2 and 3-3 illustrate possible remote control connections. Use extreme care when using a remote control connection as the High Voltage Output is being turned ON and OFF with with an external signal.

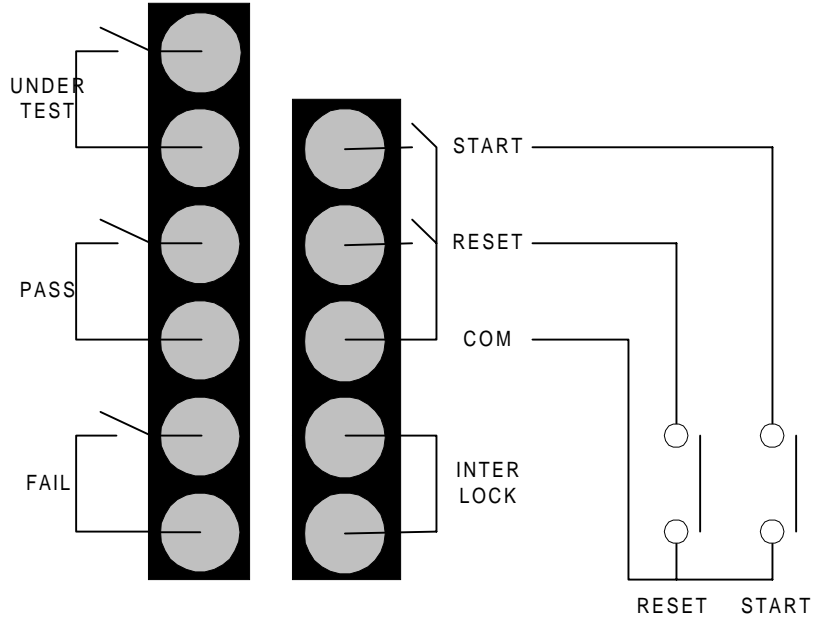

Figure 3-2: Single Control of TEST or STOP

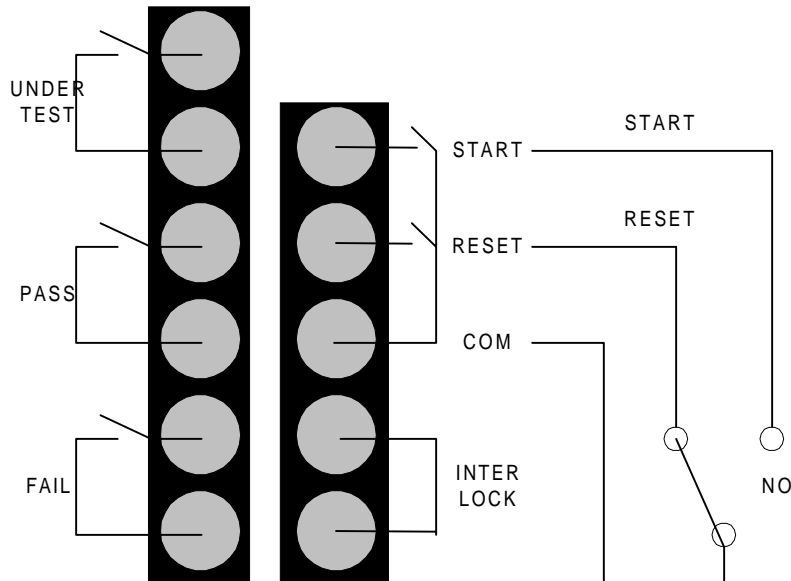

Figure 3-3: Continuous Control of STOP

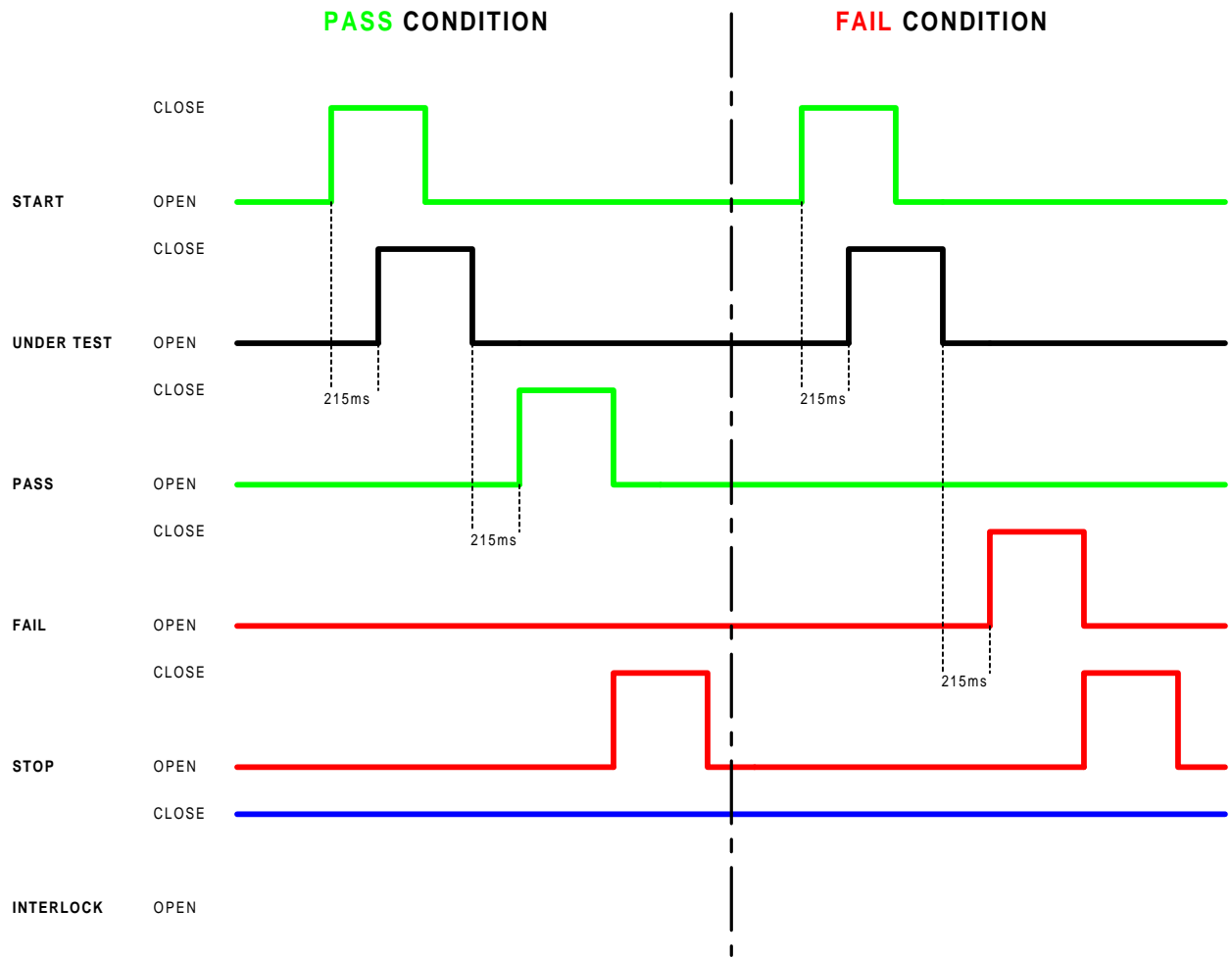

Figure 3-4: G6000 Timing Diagram

3.2 RS232 Interface

3.2.1 PIN Configuration

An optional RS232 interface is available for the Guardian 6000 instrument. The interface is factory installed when the instrument is ordered. Connection is through the black 25-PIN connector labeled 'RS232' on the rear panel of the Guardian 6000 unit. Figure 3-5 illustrates the RS232 PIN configuration.

NOTE

When the RS232 Interface and the IEEE-488 Interface are both installed in a Guardian 6000 unit, only one of the two interfaces may be activated at a time.

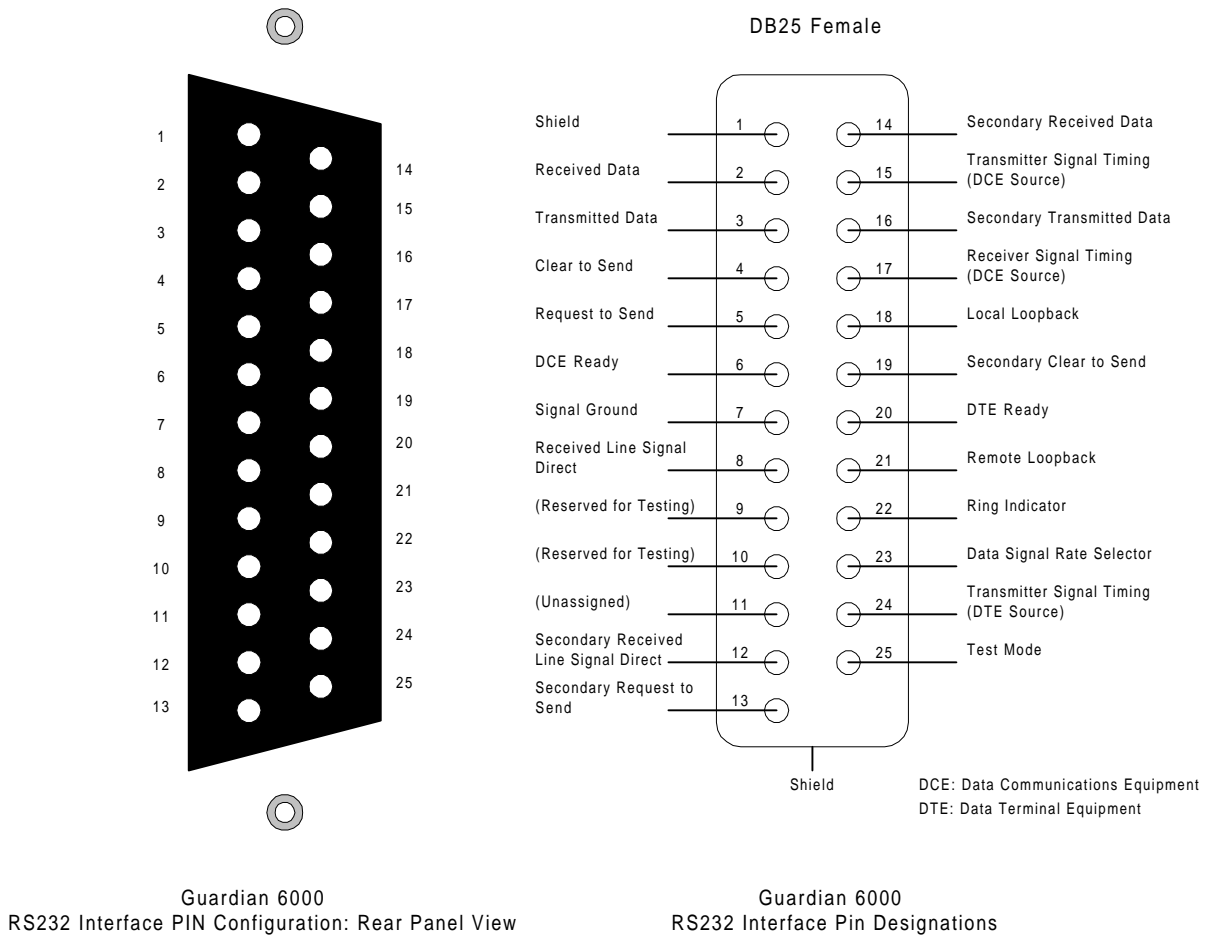

Figure 3-5: RS232 PIN Configuration

3.2.2 RS232 Specifications

Data bits: 8
Stop bits: 1
Parity: None
Baud Rate: 0.3/1.2/2.4/4.8/9.6/19.2 (k) Software Selectable
EOS: CR + LF
Echo: Off

Selecting Baud Rate

Setting the baud rate is done in the initial parameter settings, ¶ 2.12.4.2. Select the initial parameter Remote Settings, then select Baud Rate.

Parameter	Function	Default Value	Rate
Baud Rate	Select Baud Rate	9.6k	0.3 to 19.2 (kbps)

Use the numerical keys to select baud rate then press [ENTER]. Press [PROG] key to exit initial parameter settings.

3.2.3 RS232 Commands

The command set for the RS232 interface is the same as the IEEE-488 interface command set listed in paragraphs 3.3.3 through 3.3.5 of this Instruction Manual.

NOTE

CR + LF is the end code for the RS232 Commands.

3.3.4 Sample QuickBasic Program

```
CLS
REM
OPEN "com2:9600,n,8,1,rs" FOR RANDOM AS #2:

PRINT #2, "*idn?"      'get unit identification
FOR j = 1 TO 2000: NEXT j

'determine number of bytes at com port
DO WHILE (LOC(2) = 0)
FOR j = 1 TO 2000: NEXT j
LOOP
'then get the rest of the string
Y = X + LOC(2)
DO WHILE (X <> Y)
Y = X
FOR j = 1 TO 2000: NEXT j
X = LOC(2)
LOOP

'read information at com port
R$ = INPUT$(X, #2)

'print identification to screen
PRINT R$

CLOSE #2
END
```

3.3 IEEE-488 Interface

3.3.1 PIN Configuration

The Guardian 6000 instrument includes an IEEE-488 interface with connection through a blue 24-PIN connector (labeled GPIB) on the rear panel. This interface can be used to connect a system containing a number of instruments and a controller in which each meets IEEE Standard 488.2 (Standard Digital Interface for Programmable Instrumentation). Figure 3-6 illustrates the PIN Configuration of the IEEE-488 interface.

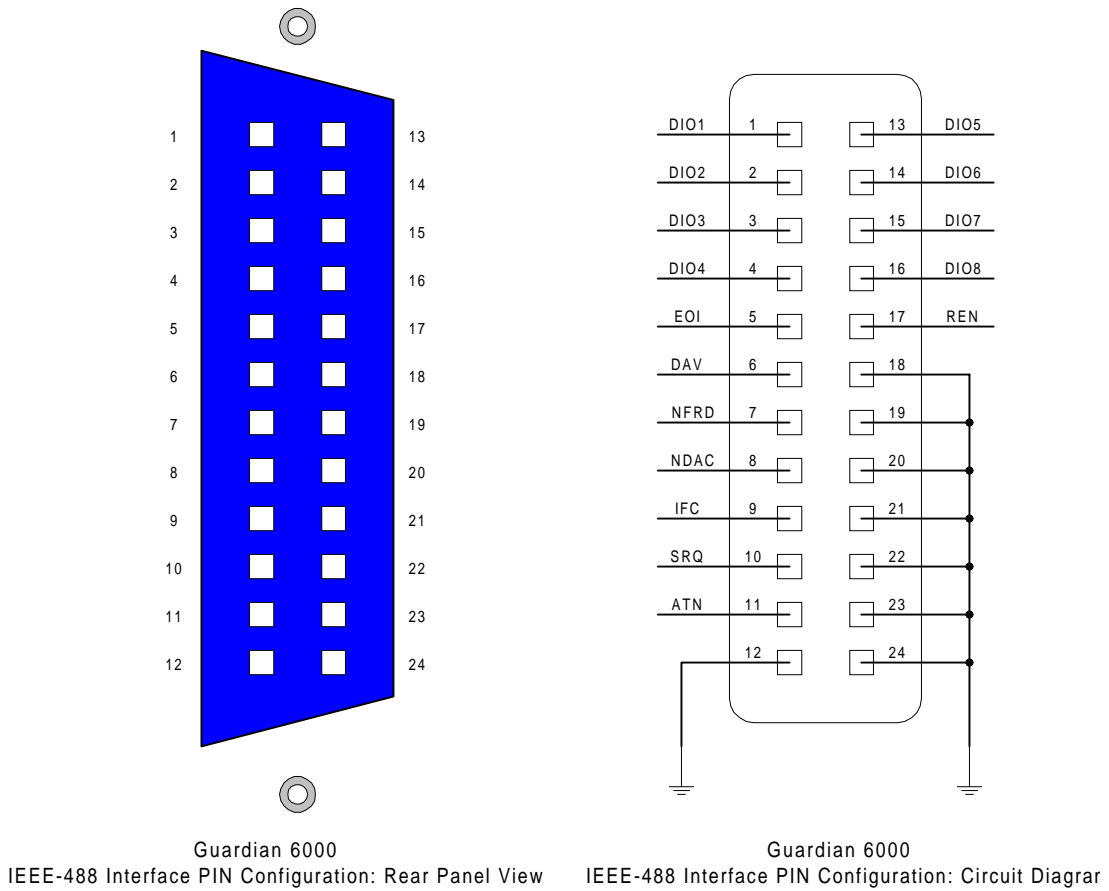

Figure 3-6: IEEE-488 Interface PIN Configuration

3.3.2 IEEE-488 Interface Codes and Messages

The IEEE-488 (GPIB) address is defined in the Initial Parameter Setting mode by selecting [Remote Setting] and [GPIB address]. Refer to paragraph 2.12.4.

The G6000 unit is in a remote control status when the REMOTE LED is ON.

To switch to Local from Remote press the [PROG] key, disabled by LLO message.

The only controls functional under Remote operation is [PROG], which switches to Local and [STOP] which resets the unit.

Table 3-1 defines the IEEE-488 interface codes and their function. Table 3-2 defines the IEEE-488 interface messages and their function.

Table 3-1 : IEEE-488 Interface Functions

Code	Function
SH1	Source Handshake
AH1	Acceptor Handshake
T4	Basic Talker Function
L4	Basic Listener Function
SR0	No Service Request Function
RL1	All Remote/Local Function
PP0	No Parallel Poll Function
DC1	All Device Clear Function
DT0	Device Trigger Function
C0	No Controller Functions

Table 3-2 : IEEE-488 Interface Messages

Interface Message	Function	Description
GET	Ground Execute Trigger	Response depends on the *DDT, setting to TEST or STOP
GTL	Go To Local	Switch unit to local
SDC	Selected Device Clear	Reset the unit
LLO	Local Lockout	Disables [PROG] switch to local
IFC	Interface Clear	Reset bus interface

3.3.3 IEEE-488 Interface Commands

The interface function is controlled by ASCII commands which include:

{[command + parameter] ; [command + parameter] + ending code}

The length of the string is 128 characters. It is not necessary to input any sign or space between the command and parameter. Any two commands can be connected by "," and [Ending Code]. Ending Code can be any type in Table 3-3.

Table 3-3 : IEEE-488 Interface Ending Codes

Ending Code
LF
CR + LF
EOI
LF + EOI
CR + LF + EOI

NOTE

The data can be sent out by the IEEE-488 interface to achieve transfer function. The data command is {string message + ending code}. The ending codes are listed in Table 3-3.

NOTE

CR + LF is the end code for the RS232 Commands.

3.3.4 Listener Functions

Table 3-4 contains the IEEE-488/RS232 Interface command list. These commands are described on the following pages in order of item number.

Table 3-4 : Command List

Item	Command	Parameter	Function
1	STOP	X	stop test
2	TEST	X	start test
3	SHOW (?)	{c}	set testing value
4	STEP (?)	{n}	set Step
5	MODE (?)	{n c}	set test mode
6	SOUR (?)	{f}	set output voltage or current
7	VOLT (?)	{f}	set output voltage
8	CURR (?)	{f}	set output current
9	HILI (?)	{f *}	set High Limit
10	LOLI (?)	{f *}	set Low Limit
11	SARC (?)	{f *}	set ARC
12	BOXN (?)	{n}	Set Box number
13	HICH (?)	{n *}	set High Channel
14	LOCH (?)	{n *}	set Low Channel
15	TIME (?)	{f *}	set the test time
16	RAMP (?)	{f *}	set the voltage rise time
17	OFST (?)	{c}	set offset
18	*SAV	{n}	save the setting value
19	*RCL	{n}	read the setting value
20	CLER	X	clear the memory
21	*IDN (?)	X	check the unit number
22	*DDT (?)	{n c}	set the response to Trigger
23	*TRG	X	execute Trigger command
24	*RST	X	reset the unit
25	DEV(?)	{n}	selects LC Device
26	LINE(?)	{n}	selects LC Line Input
27	POWER(?)	{n}	selects LC Power
28	PWHI(?)	{f *}	set Power High Limit
29	PWLO(?)	{f *}	set Power Low Limit

Where

- x: no parameter required
- n: indicates integer
- f: indicates floating
- c: indicates memory mark
- *: indicates the "*" character of ASCII

1. STOP

Stop testing, same as STOP on front panel.

2. TEST

Start testing, same as START on front panel.

3. SHOW (?) {c}

Set and check the testing value, [STATUS] [STEP] [MODE] [SOURCE] [MEASURE] [TIMER] [CHAN] [SAVE]

The command can connect each parameter with "|". Each parameter can be abbreviated. Ex: STA=STATUS, STE=STEP, SO=SOURCE, SA=SAVE

A delay \geq 150 msec should be used between commands during measurements.

4. STEP (?) {n}

Set step number (1 - 10). Set step number first before setting test conditions for that step.

5. MODE (?) {n | c}

Set test mode by number or memory sign.

Mode	Number	Memory Sign
Ground Bond	0	G or GR
AC Hipot	1	A or WA
DC Hipot	2	D or WD
Insulation Resistance	3	I or IR
LC Leakage Current	4	L or LC

If testing mode is changed the test conditions will be cleared to the initial value.

6. SOUR (?) {f}

Set the output voltage of current according to mode selected.

Mode	SOURCE Output
Ground Bond	f = 1 - 30 Amp
AC Hipot	f = 0.01 - 5.0 KV
DC Hipot	f = 0.01 - 6.0 KV
Insulation Resistance	f = 50 - 1000 V
LC Leakage Current	f = 0.05 – 0.4KV

The output voltage for current can be set by SOUR or VOLT or CURR directly. **VOLT or CURR is the recommended method to avoid improper setting** (5 Amp could be interchanged for 5 KV, depending on the MODE selected).

For Ground Bond the high resistance limit is determined by the current setting. The maximum high resistance limit is 510mΩ or $R = 6.3 \text{ V/I}$ (i.e. if the current is 30 Amps the high limit could not exceed 210mΩ).

7. VOLT (?) {f}

Set the output voltage (similar to SOUR). Indicates error 1 if mode is selected for Ground Bond.

8. CURR (?) {f}

Set the output current (similar to SOUR). Indicates error 1 if mode is selected for anything other than Ground Bond.

9. HILI (?) {f | *}

Set the high limit value according to mode selected. * disables the high limit.

Mode	High Limit
Ground Bond	f = 0.1 - 500.0 mΩ
AC Hipot	f = 0.01 - 40.00 mA
DC Hipot	f = 0.01 - 20.00 mA
Insulation Resistance	f = 1 - 9999 MΩ
LC Leakage Current	f = .0001 – 9.999 mA

In Hipot mode if the High Limit is smaller than the Low Limit, the low limit is disabled. In IR mode the value can not be smaller than the Low Limit, otherwise error 2 is indicated. In Ground Bond mode the maximum high resistance limit is 510mΩ or $R = 6.3 \text{ V/I}$ (i.e. high resistance limit is 210mΩ for 30 Amps).

10. LOLI (?) {f | *}

Set the low limit value according to mode selected. * disables the low limit.

Mode	Low Limit
Ground Bond	f = 0.1 - 500.0 mΩ
AC Hipot	f = 0.01 - 40.00 mA
DC Hipot	f = 0.01 - 20.00 mA
Insulation Resistance	f = 1 - 9999 MΩ
LC Leakage	f = .0001 – 9.999 mA

In Hipot mode the low limit is disabled if greater than High Limit.
 In IR mode the low limit is disabled if greater than the High Limit.
 In Ground Bond mode the low limit can not be set.

11. SARC (?) {f | *}

Set the arc limit value.

* disables the limit.

Mode

Arc Limit

AC Hipot

f = 0.1 - 40.00 mA

DC Hipot

f = 0.1 - 20.00 mA

12. BOXN (?) {n}

Select scan box.

n : 1 – x, x is determined by number preset in initial parameter setting (§ 2.12).

If more than one scan box is being used, use this command to select the scan box before the high and low channels are set.

13. HICH (?) {n | *}

Set the High Channel, n : 1 - 8.

* disables the limit.

More than one channel is possible (Ex: HICH 1| 3| 5).

14. LOCH (?) {n | *}

Set the Low Channel, n : 1 - 8.

* disables the limit.

More than one channel is possible (Ex: LOCH 1| 3| 5).

Can not be set in Ground Bond mode.

15. TIME (?) {f | *}

Set the Test Time, f : 0.1 - 999 sec. * disables the timer.

If the disable timer is set to TEST ON, the unit will remain in TEST ON status.

16. RAMP (?) {f | *}

Set the voltage rise time, f : 0 - 99.9 sec. * disables the timer.

Ramp Time is set in AC or DC Hipot Mode only.

17. OFST (?) {c}

Set or examine the offset value.

C : is a word character or abbreviation

“GET” : set a scratch status. “OFF” : close the offset function

“STOP” command makes “OFST GET” = “OFST OFF”.

18. *SAV {n}

Save the test conditions for later recall (up to 10 steps each) in memory location

n : 1 - 50.

19. *RCL (?) {n}

Recall the test conditions that have been saved (up to 10 steps each) in memory location, n : 1 - 50.

20. CLER

Resets the instrument from interface control.

All data is erased except the GPIB address and the RS232 Baud Rate.

21. *IDN ?

Checks the instrument for identification (unit number).

The unit number is displayed after entering the command "Zentech 9032A"

22. *DDT (?) {n | c}

Determines the response from the interface when the instrument receives TRG or GET command.

"0" or "S"	Stop testing
"1" or "T"	Start testing
"2" or "NS"	Stops testing after receiving "*TRG" or "GET" command and "*DDT" will change to "NT".
"3" or "NT"	Starts testing after receiving "*TRG" or "GET" command and "*DDT" will change to "NS".

23. *TRG

Triggers the instrument and functions the same as interface message GET.

This is dependent on the setting of DDT, see 23 above.

24. *RST

Resets the instrument and functions the same as interface message SDC.

25. DEV(?) {n}

Select the LC Device (Human Circuit Model), n : 1 - 5.

1 = UL544NP, 2 = UL544P, 3 = UL1563, 4 = UL2601-1, 5 = UL1950

26. LINE(?) {n}

Select the LC Line Input (Fault Simulation), n : 0 - 3.

0 = Normal, 1 = Reverse, 2 = Single fault normal, 3 = Single fault reverse

27. POWER(?) {n}

Select the DUT Power Monitor, n : 1 - 3.

1 = Voltage, 2 = Current, 3 = VA

28. PWHI(?) {f | *}

Set HIGH Power Limit (for DUT Power Monitor)

f: 0 – 300V, f: 0.001 – 9.999mA, f: 0 – 2200VA * disables the limit.

29. PWLO(?) {f | *}

Set LOW Power Limit (for DUT Power Monitor) f : 0.001 – HIGH Limit

* disables the limit.

3.3.5 Talker Functions

The message of {string + ending code} will be sent when the instrument is assigned as TALKER. The ending code consists of CR+LF+EOI. The string is dependent on the present status. There are several commands with the "?". These commands send the testing value by ASCII string.

- EXAMPLE :
1. Command : mode WD: mode?
:MODE 2 : With Standing DC voltage test mode.
 2. Command : high 1|3|5; high?
:HICH 1|3|5 : High Channel 1,3,5 is ON

All commands will feed back an error message except *RST, *TRG , show and "?". If the error code is not 0 the result will be displayed. Error messages are shown in Table 3-5.

Table 3-5 : IEEE-488 Interface Error Messages

Error Messages
Error 0: Save OK!
Error 1: The command is not valid
Error 2: The parameters are not valid
Error 3: Can not start test
Error 4: Scanner is not connected
Error 5: Channel can not set 0
Error 6: Channel invalid

The TALKER function is completed by SHOW(?) command. The instrument will send back the testing value for the parameter selected. It may check more than one test value by connecting the parameters with "|". Status messages are shown in Table 3-6.

Table 3-6 : IEEE-488 Interface Status Messages

Status Messages
Status 0: Presently in STOP status
Status 1: Presently in TEST status
Status 2: Test complete, condition is PASS
Status 3: Test stop, condition is FAIL
Status 4: Test stop, Hipot arc limit FAIL
Status 5: Test stop, Hipot high limit FAIL
Status 6: Test stop, Hipot low limit FAIL
Status 7: Test stop, IR high limit FAIL
Status 8: Test stop, IR low limit FAIL
Status 9: Test stop, GR high limit FAIL
Status A: Test stop, Charge Low limit FAIL

1. STATUS

To check the present status, with status code.

Output form is : STATUS_X--8 bytes

NOTE : "_" denotes a space

2. STEP

To check the present step.

Output form is : STEP_XX--7 bytes

3. MODEL

To check the testing mode.

Output form is : MODE_X--6 bytes

4. SOURCE

To check the output voltage or current.

Output form is :

1) GR Mode	AC_XX.XX_A	
2) AC Mode	AC_X.XXX_kV	
3) DC Mode	DC_X.XXX_kV	
4) IR Mode	DC_XXXX_V	
5) LC Mode	AC_X.XXX_kV	total: 11 bytes

5. MEASURE

To check the tested resistance or current.

Output form is : MEASURE_XXXXX_UU total: 16 bytes
where XXXXX is the measured value
and UU the units.

6. TIMER

To check the test time remaining.

Output form is :

1) TIME_XXX.X	
2) RAMP_XXX.X	total: 10 bytes

7. CHAN

To check the channel status.

Output form is : HICH_X|X||X, LOCH_X|X|.....|X
total: 13 to 41 bytes

8. SAVE

To save the data of each test. The unit can read the data without the SHOW parameter.

9. Meas:all?

To return source and measure data for all steps at the end of the measurement.

Similar to show SOURCE or MEASURE.

Example: How to Display saved results (#8 SAVE)

Write : "SHOW Step|save"

Read : STEP 1

Read : STEP 1

Write : "SHOW mode"

Read : MODE 1

Read : STEP 1 shows step by pressing "SHOW step|save"
"SAVE" parameter can not be used alone

SHOW SAVE will display Error 2

If the instrument is required to display saved item, just use "SHOW?" command

If the instrument is required to display more than one testing value, no matter what the order of parameters, the output will display the following.

[STATUS], [STEP],[MODE],[SOURCE],[MESSAGE],[TIMER],[CHAN]

Any two parameters are separated by a ","

Example: Write: "SHOW STEP|STATUS|MODE"

Read: STATUS 2, STEP 1, MODE 1

The string length sent by SHOW may not be more than 107 bytes (including ending code)

3.3.6 Sample QuickBASIC Program

```
REM $INCLUDE: 'qbdecl.bas'
'declarations
ADAP$ = "GPIB0": G6000$ = "DEV3": V% = 1
W% = 0: C$ = SPACE$(50): d$ = SPACE$(50): C1$ = SPACE$(50): D1$ =
SPACE$(50)
STAT$ = SPACE$(50)

'find IEEE card and G6000
CALL IBFIND(ADAP$, GPIB0%)
CALL IBFIND(G6000$, G6000%)

CLS 'clear screen

'read identification from g6000
CALL IBWRT(G6000%, "*IDN")
CALL IBRD(G6000%, D1$)
PRINT D1$

'open a file to store data and status to
20
PRINT "FILE NAME TO STORE RESULT (less than 8 characters)"
INPUT NAMES$
IF LEN(NAMES$) = 0 THEN NAMES$ = "DATA"
IF LEN(NAMES$) > 8 THEN GOTO 20
NAMES$ = NAMES$ + ".TXT"
OPEN NAMES$ FOR APPEND AS #1

'ask user for mode, voltage, current, ramp and test time
50
PRINT "MODE 1 = AC, 2 = DC"
INPUT MODE$
IF MODE$ = "" OR MODE$ > "2" OR MODE$ < "1" THEN GOTO 50 'check mode is
AC/DC hipot
100
PRINT "INPUT VOLTAGE IN kV"
INPUT VOLT$
IF VOLT$ = "" OR VOLT$ > "5" THEN GOTO 100 'check voltage is in range
200
PRINT "HIGH CURRENT LIMIT IN mA"
INPUT CURR$
IF CURR$ = "" OR CURR$ > "40" THEN GOTO 200 'check current is in range
PRINT "RAMP TIME IN seconds"
INPUT RAMP$
```

```

300
PRINT "TEST TIME IN seconds"
INPUT TIM$
IF TIM$ = "" OR TIM$ > "999.9" THEN GOTO 300 'check time is in range

'configure g6000
SET$ = "STEP1;MODE" + MODE$ + ";SOUR " + VOLT$ + ";HILI" + CURR$ +
";RAMP" + RAMP$ + ";TIME" + TIM$
CALL IBWRT(G6000%, SET$)          'send string to g6000
REM CALL IBRD(G6000%, C$)         'read status of g6000

'perform a measurement
CALL IBWRT(G6000%, "STOP") 'make sure unit is in stop mode
CALL IBRD(G6000%, C$)      'read status
PRINT C$
CALL IBWRT(G6000%, "TEST") 'start measurement
FOR I = 1 TO 500
NEXT I
CALL IBWRT(G6000%, "SHOW STATUS") 'check status of unit
CALL IBRD(G6000%, STAT$)
WHILE VAL(MID$(STAT$, 8, 1)) = 1 'loop while status is testing
    CALL IBWRT(G6000%, "SHOW STATUS")
    CALL IBRD(G6000%, STAT$)
    PRINT STAT$
WEND

'get data from G6000
CALL IBWRT(G6000%, "SHOW SOURCE|MEASURE") 'ask for voltage and current
levels
CALL IBRD(G6000%, d$) 'read current and voltage levels
PRINT "DATA IS: "; d$ 'output data to the screen
PRINT #1, d$ + STAT$ + TIME$ + " " + DATE$ 'store data and status to open file
CLOSE #1

END

```

3.4 Printer Interface

An optional Printer Interface is available for the Guardian 6000 instrument. **The Printer interface takes the place of the IEEE-488 interface** and is factory installed when the unit is ordered. Connection is through the black 25-PIN connector labeled 'GPIB' on the rear panel of the G6000 unit. Figure 3-7 illustrates the Printer interface PIN Configuration.

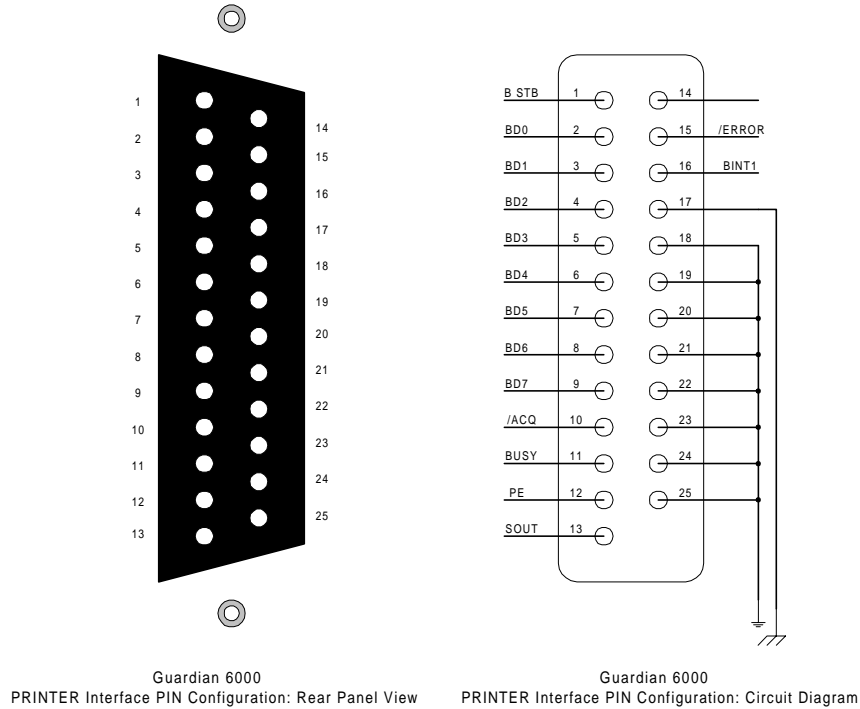

Figure 3-7: Printer Interface PIN Configuration

A typical printer output for a 3-Step Pass is illustrated below followed by Step 2 which is designated 'Fail for Low'.

STEP-01 Pass 0.0s
0.998kV WAC 0.018mA

STEP-02 Pass 0.0s
1.998kV WDC 0.001mA

STEP-03 Pass 0.0s
0.2V LC 0.003mA

STEP-01 Pass 0.0s
0.998kV WAC 0.018mA

STEP-02 Low 0.0s
1.998kV WDC 0.001mA

3.5 Scanner Interface

3.5.1 Scanner Accessories

The Scanner Interface is a standard accessory on the Guardian 6000 instrument. The Scanner interface is factory installed when the unit is ordered. Connection is through the black 25-PIN connector labeled 'SCAN' on the rear panel of the Guardian 6000 instrument. The Guardian 6000 unit may be used with a scan unit for multi-point grounding and hipot tests. Table 3-7 displays the scanner accessories available for the G6000 unit. Figure 3-8 illustrates the four Plug-In Scanner options (P/N 6000-01, -02, -03 & -04).

Table 3-7 : Guardian 6000 Scanner Accessories

Item	Qty	QT P/N
25 pin interconnect cable (G6000 to Scanner)	1	G17
Hipot Test Lead Set (G6000 to Scanner I/P)		
HV plug to sheathed banana plug (red)	1	G18
Banana Plug (with retaining bracket) to sheathed banana plug (black)	1	G19
Hipot Scan Clip Leads (Scanner to front panel outputs of DUT)		
Sheathed banana plug (orange) to alligator clip (red)	8	G21
GC Interconnect Cable (G6000 output to Scanner rear panel GC input)		
Banana plug/lug (red/black) to banana plug/lug (red/black)	1	G20*
GC Scan Clip Lead Set (Scanner rear panel GC outputs to DUT)		
Large alligator clips (red/black) to banana plug/lug (red/black)	4	G15*
Scan Card for G6000	1	700120
Internal (Plug-in) Scanner: 3 Ground Continuity/5 High Voltage Channels	1	6000-01
Internal (Plug-in) Scanner: 5 Ground Continuity/3 High Voltage Channels	1	6000-02
Internal (Plug-in) Scanner: 8 High Voltage Channels	1	6000-03
Internal (Plug-in) Scanner: Line Leakage Scanner	1	6000-04
Corded Product Adaptor for 6000-04 Line Leakage Scanner	1	G30
500VA Isolation Transformer for 6000-04 Line Leakage Scanner	1	G31
1000VA Isolation Transformer for 6000-04 Line Leakage Scanner	1	G32

* Included with GC Scanner only (6000-01, 6000-02 and 5000-02).

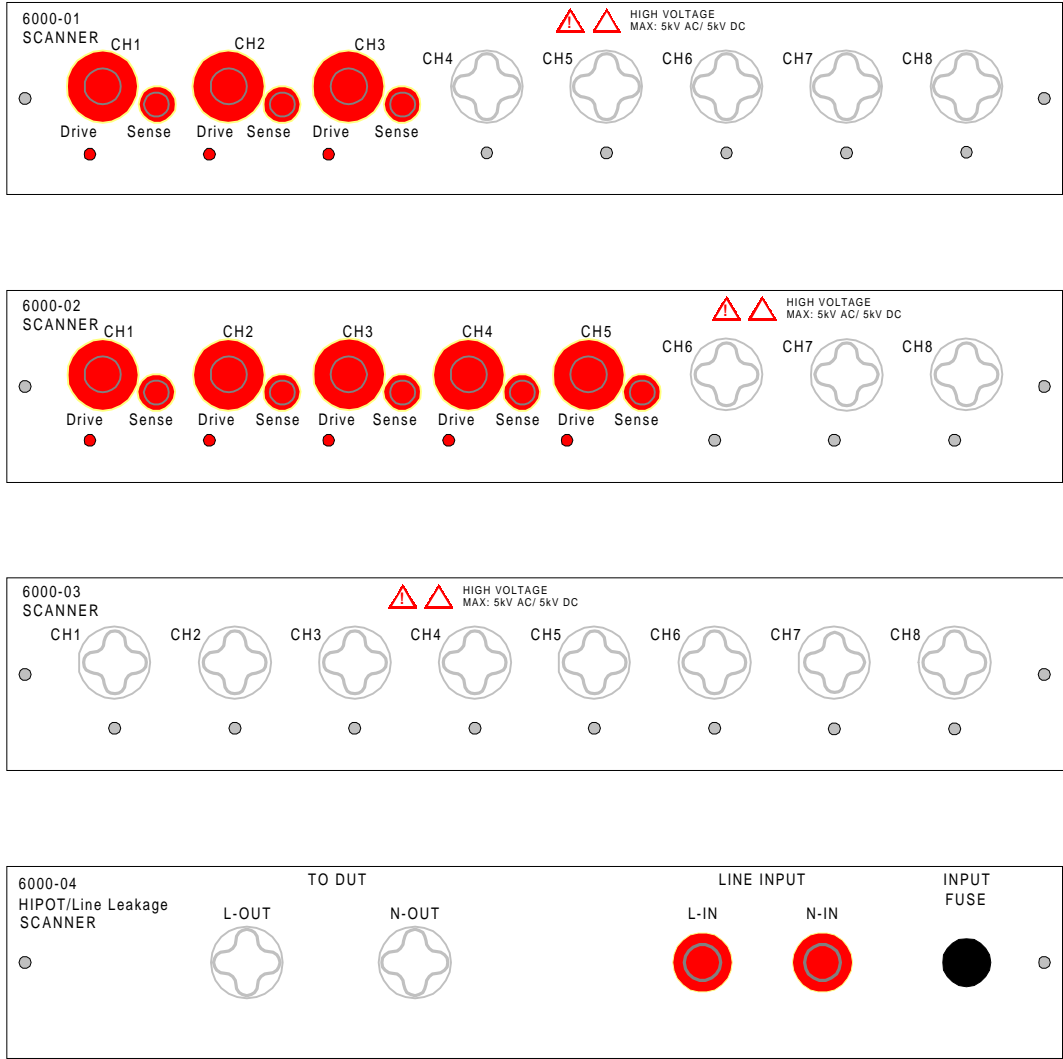

Figure 3-8: G6000-01, -02, -03 and -04 Internal (Plug-in) Scan Units

3.5.2 Scanner Card Installation

No installation of a scanner card is necessary with the Guardian 6000-01, -02, -03 or -04 plug-in scanners. Scan units and applicable hardware are factory installed when the purchase order is placed.

3.5.3 Scanner Connections

Before connecting the scanner to the Guardian 6000 or connecting devices for test, **press the [STOP] key** and make sure the red **DANGER** light is **OFF**. Figures 3-9 to 3-11 illustrate connection of the G6000 to scanners.

The G17 25-PIN SCAN control cable is connected from the G6000 rear panel SCAN connector to the 5000-01 rear panel SCAN I/P connector.

The G18 lead set connects the HV terminals. The white ‘Star’ plug is connected to the G6000 front panel HV output terminal and the red banana plug is connected to the 5000-01 front panel HV I/P terminal.

The G19 lead set connects the GND terminals. The black banana plug with retaining bracket is connected to the G6000 front panel GND output terminal and the black banana plug is connected to the 5000-01 front panel LOW I/P terminal.

Interconnect the Rear Panel Ground Lugs (Chassis Ground, silver screw/banana plug) using a banana to banana cable or banana to u-clip cable. This assures that the scanner(s) retains connection to earth ground.

WARNING
THE REAR PANEL GROUND LUGS ON ALL INSTRUMENTS (Guardian 6000 and Scanners) MUST BE INTERCONNECTED

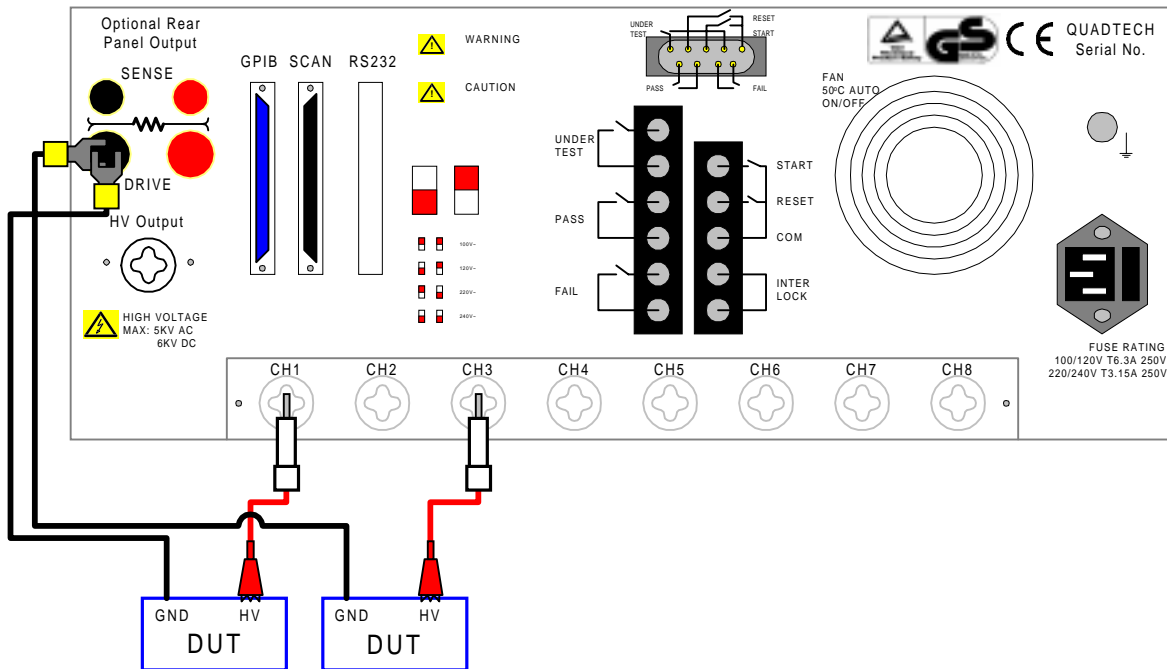

Figure 3-9: 6000-03 Scanner Connection to DUT

3.5.4 External Scanner Programming

There are 16 indicators (8 high, 8 low) on the scanner front panel, during test these indicate which are programmed for the High Voltage or Low connections. Connections for high voltage are indicated in red and low in green. When the scanner and Guardian 6000 are connected (25 pin interconnect cable) the instrument will accept entry of scanner connections. A **High** or **Low** entry is made during the programming process preceding the entry of a test voltage. It is possible to have one or multiple entries for scanner connections, i.e. if 1 ,2 and 3 are entered for the Hi connection all three outputs will be connected to the High Voltage terminal during the test.

Programmed Scanner Connections as Shown in Figures 3-9 and 3-10

When using one scanner, the **scan box channels 1-8** can be programmed high or low prior to entering the test voltage. Use the numerical keys and enter high scan channels. Press [ENTER]. Use the numerical keys and enter low scan channels. Press [ENTER].

High = 1 2 3 Scan Box-Channel 1

Low = 4 5 6 7 8 Scan Box-Channel 1

Programmed Scanner Connections as Shown in Figure 3-11

When using more than one scanner, the **initial parameter setting: Scan No** must be setup for the number of scanners connected. Refer to paragraph 2.12. Connection of up to 8 scanners (6000-01) for hipot or IR testing is possible for a total of 64 channels. Ground bond testing is limited to 1 scanner (6000-02) for a total of 4 channels. When programming scanner connections the scanner number (1 through 8) is shown on the display.

NOTE

When the scanner is programmed for multiple connections in the same test step the devices under test are connected in parallel (as shown in Figures 3-10 and 3-11). To test several devices independent from each other, requires an individual test step (1 to 15) for each. Refer to paragraphs 2.3 – 2.7.

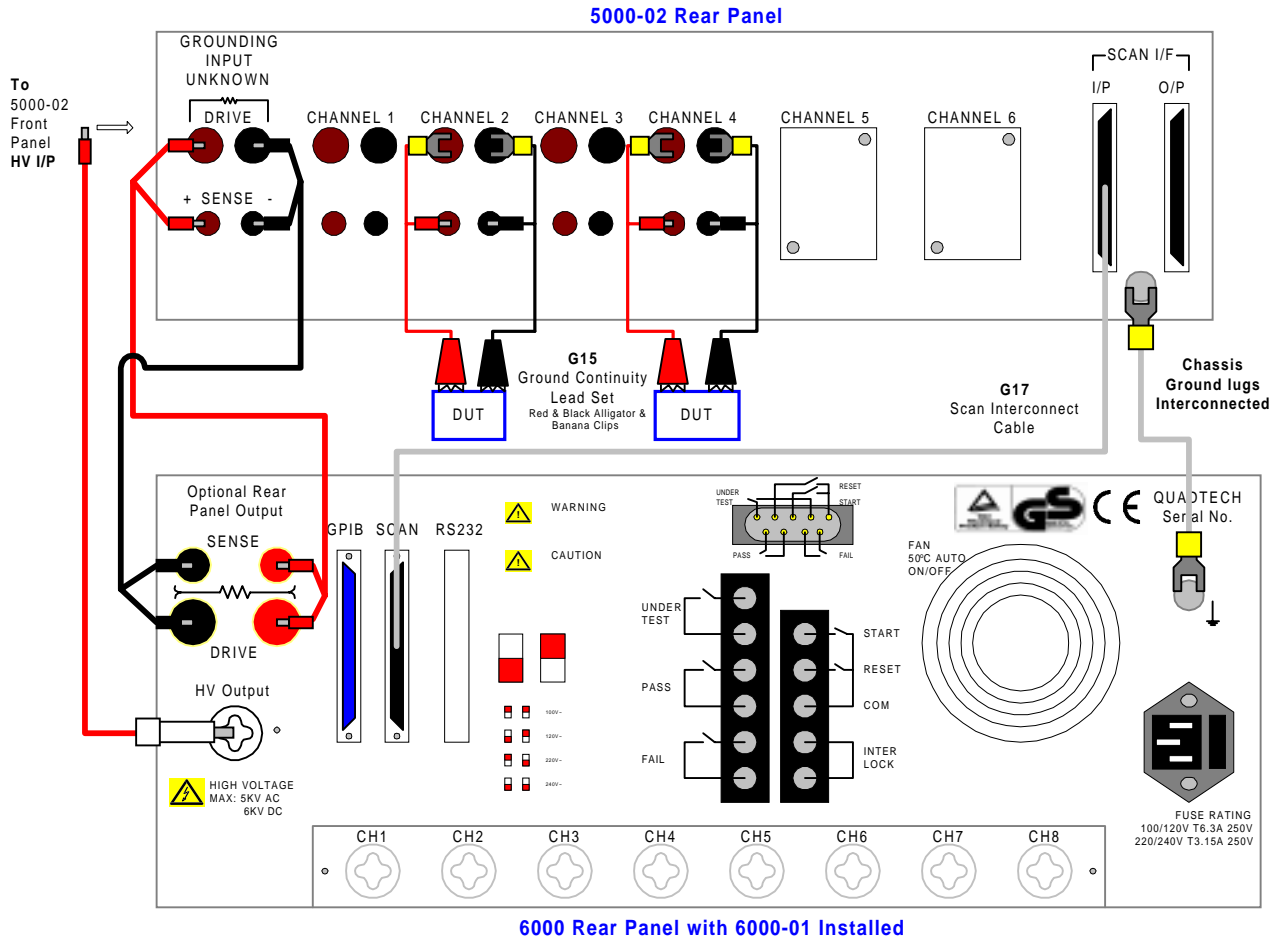

Figure 3-10: Guardian 6000 Connection to 5000-02 External Scanner (GR Test)

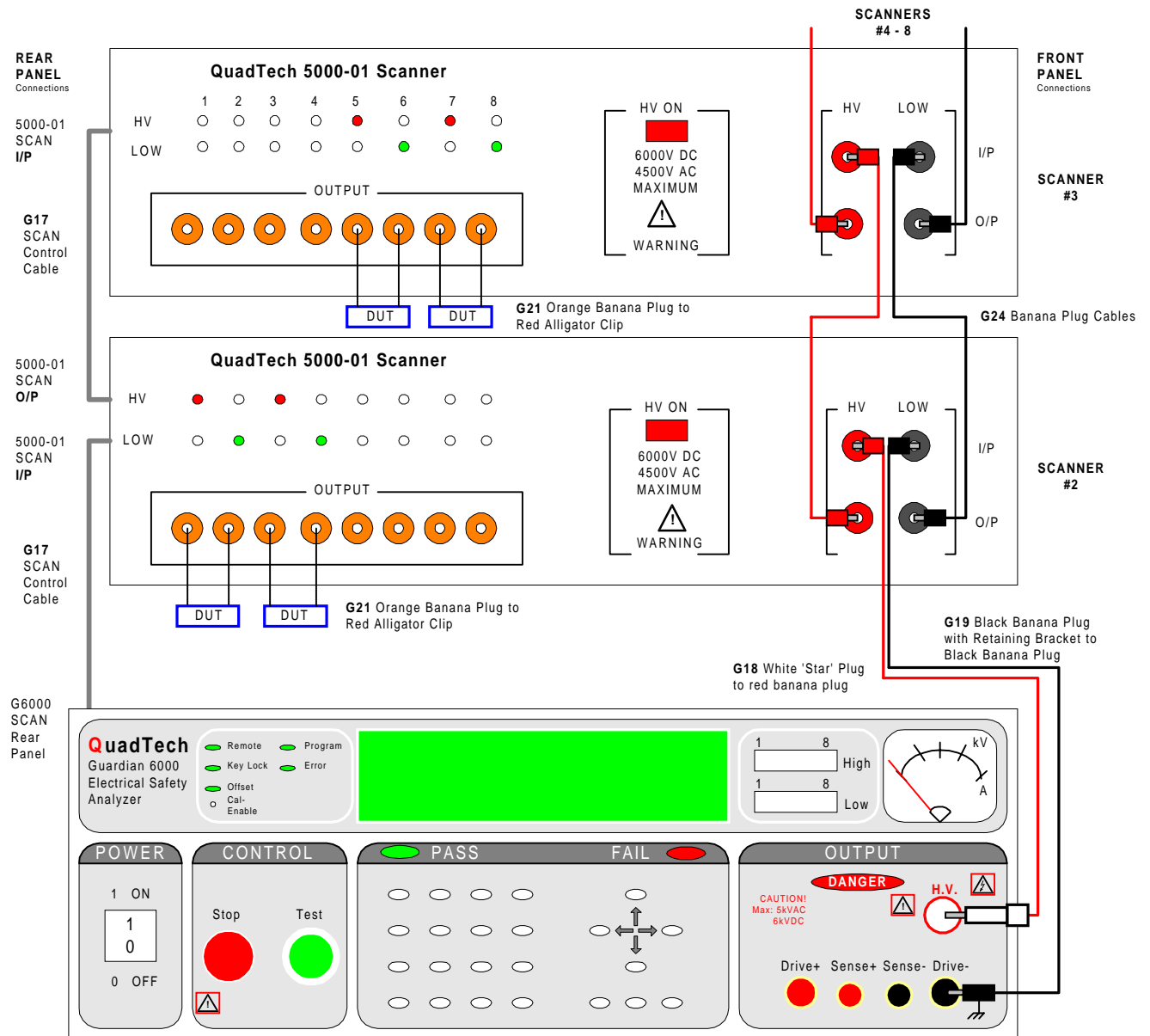

Figure 3-11: Guardian 6000 Connection to 5000-01 Multiple External Scanners (AC/DC Hipot & Insulation Resistance Tests)

3.6 G16 International Power Strip

The G16 International Power Strip allows connection of standard corded products from several different countries. These countries are:

- | | | |
|-----------------|------------------|---------------|
| * Australia | * United Kingdom | * Denmark |
| * North America | * Norway | * |
| Finland | | |
| * Sweden | * Germany | * Netherlands |
| * Austria | * Switzerland | * Italy |

Refer to Figure 3-12 for connection of the G16 International Power Strip to the Guardian 6000 instrument output terminals.

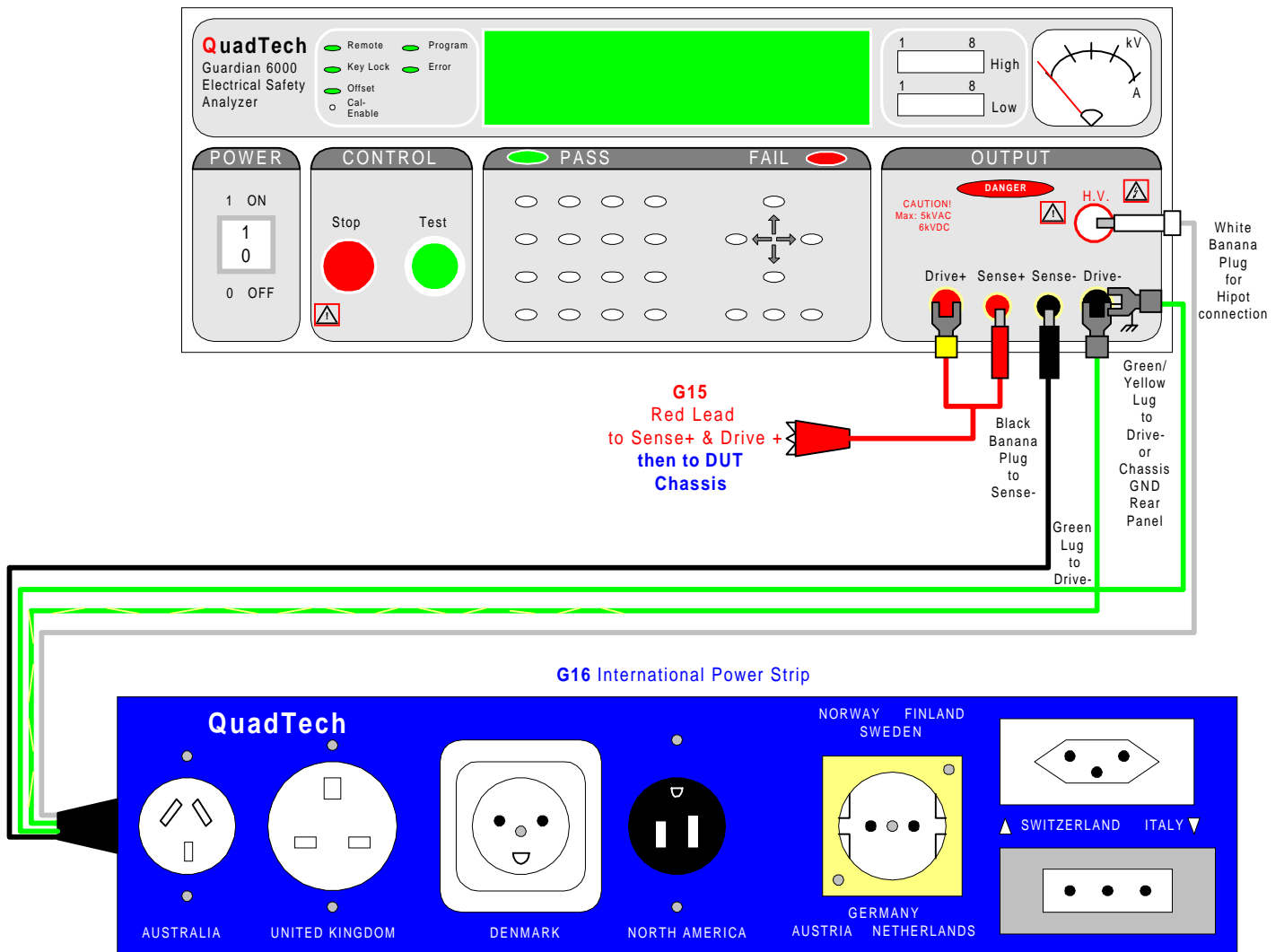

Figure 3-12: G16 International Power Strip Connection

3.7 G-14 Power Entry Adaptor Cable

The G-14 Power Entry Adaptor Cable allows an AC inlet connection of product to Guardian 6000 unit through a three lead set. The leads consist of a white plug for connection to HV output, a black banana plug with retaining bracket for connection to the Sense- terminal, and a black spade lug for connection to the Drive- terminal. Figure 3-13 illustrates the connection of the G-14 Power Entry Adaptor Cable to the Guardian 6000 unit.

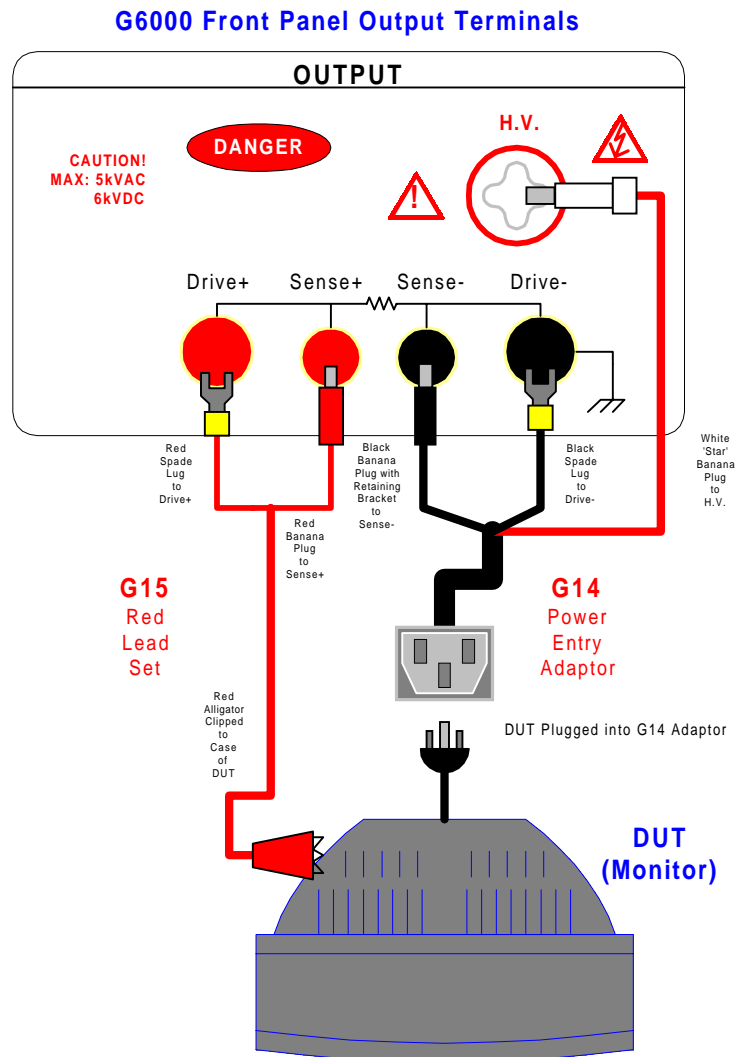

Figure 3-13: G-14 Power Entry Adaptor Cable Connection

3.8 G-13 Corded Product Adaptor

The G-13 Corded Product Adaptor allows a three prong receptacle connection for product to Guardian 6000 unit through a three lead set. The leads consist of a white plug for connection to HV output, a black banana plug for connection to the Sense- terminal, and a black spade lug for connection to the Drive- terminal. Figure 3-14 illustrates the connection of the G-13 Corded Product Adaptor to the Guardian 6000 unit.

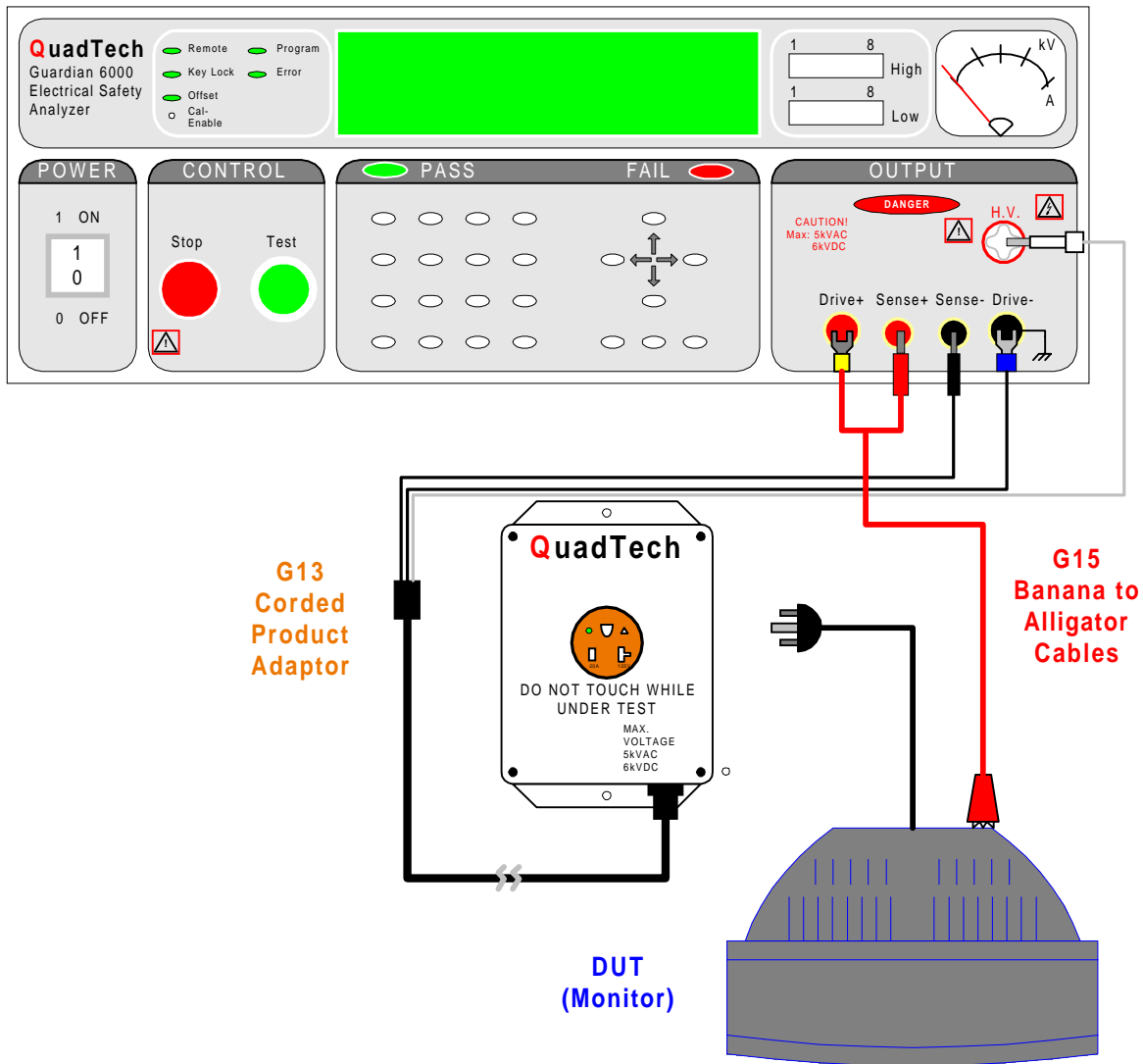

Figure 3-14: G-13 Corded Product Adaptor Connection

Section 4 : Service & Calibration

4.1 General

Our warranty (at the front of this manual) attests to the quality of materials and workmanship in our products. If malfunction should be suspected or other information be desired, applications engineers are available for technical assistance. Application assistance is available in the U.S. by calling 978-461-2100 and asking for Applications Support. For support outside of the United States please contact your local QuadTech distributor.

4.2 Instrument Return

Before returning an instrument to QuadTech for service please call our **Customer Care Center (CCC)** at **800-253-1230** for return material authorization (RMA). It will be necessary to include a Purchase Order Number to insure expedient processing, although units found to be in warranty will be repaired at no-charge. For any questions on repair costs or shipment instructions please contact our CCC Department at the above number. To safeguard an instrument during storage and shipping please use packaging that is adequate to protect it from damage, i.e., equivalent to the original packaging and mark the box "Delicate Electronic Instrument". Return material should be sent freight prepaid, to:

QuadTech, Inc.
5 Clock Tower Place, 210 East
Maynard, Massachusetts 01754

Attention: RMA #

Shipments sent collect can not be accepted.

4.3 Calibration

Calibration of the Guardian 6000 is recommended on an annual basis. If the unit is returned to QuadTech for factory calibration refer to paragraph 4.2 for instructions. Using the calibration procedure below the instrument can be calibrated by a qualified service person if traceable calibration equipment and standards are available. **The instrument should be powered up for a minimum of 1 hour before calibration to ensure maximum stability.**

Table 4-1 : Calibration Equipment

Equipment	Parameter	Requirements
AC/DC High Voltage Voltmeter		Measure Range : 0 to 6KV, 0.1% accuracy
AC/DC Current Meter		Measure Range : 0 to 40mA, 0.1% accuracy
1GΩ Resistance Standard	IR Resistor	250V
100MΩ Resistance Standard	IR Resistor	500V
10MΩ Resistance Standard	IR Resistor AC & DC Current	500V & 1000V 1200V, 0.1mA, .25W
500KΩ Resistance Standard	Leakage Current	200V, 0.4mA, .25W
480KΩ Resistance Standard	AC & DC Current	1200V, 3mA, 50W
250KΩ Resistance Standard	ARCing	1250V, 5mA, 5W
100KΩ Resistance Standard	Leakage Current	400V, 4mA, 50W
80KΩ Resistance Standard	DC Current	1200V, 15mA, 100W
45KΩ Resistance Standard	AC Current	1200V, 25mA, 200W
100mΩ Resistance Standard	Ground Continuity	200W
50mΩ Resistance Standard	Ground Continuity	
10mΩ Resistance Standard	Ground Continuity	

4.3.1 Calibration Procedure

Table 4-2 details the calibration parameters of the Guardian 6000 instrument.

Table 4-2 : Calibration Parameters

TEST		RANGE		CAL. POINT
Voltage Calibration				
CAL	ACV	5kV	OFST	0.050 KV
CAL	ACV	5kV	FULL	4.000 KV
CAL	DCV	6kV	OFST	0.050 KV
CAL	DCV	6kV	FULL	4.000 KV
CAL	IR	1kV	OFST	0.050 KV
CAL	IR	1kV	FULL	1.000 KV
Current Calibration				
CAL	ACA	3mA	OFST	0.120 mA
CAL	ACA	3mA	FULL	2.500 mA
CAL	ACA	40mA	OFST	2.50 mA
CAL	ACA	40mA	FULL	25.00 mA
CAL	DCA	3mA	OFST	0.120 mA
CAL	DCA	3mA	FULL	2.500 mA
CAL	DCA	20mA	OFST	2.50 mA
CAL	DCA	20mA	FULL	12.00 mA
Ground Continuity Calibration				
CAL	GRA	30A	OFST	3.00 A
CAL	GRA	30A	FULL	25.00 A
CAL	GRV	8V	OFST	3.00A
CAL	GRV	8V	FULL	30.00A
WAC and WDC ARCing Calibration				
CAL	AC ARC	40mA	Arc	5.00mA
CAL	DC ARC	20mA	Arc	5.00mA

Table 4-2 : Calibration Parameters (Continued)

Leakage Current Mode Calibration				
CAL	LCA	10mA	OFST	0.400 mA
CAL	LCA	10mA	FULL	4.000 mA
IR Resistor Mode Calibration				
CAL	RnG0	1.00 GΩ	IRR	Range 1 to 1.00GΩ
CAL	RnG1	100.0 MΩ	IRR	Range 2 to 100.0MΩ
CAL	RnG2	10.0 MΩ	IRR	Range 3 to 10.0MΩ
CAL	RnG3	1.00MΩ	IRR	Range 4 to 10.0MΩ

To Enable Calibration:

The Guardian 6000 instrument requires a minimum 30-minute warm up period prior to calibration. With the instrument in standby status ([Stop] button previously pressed and no lights flashing) remove the front panel calibration seal and push (using tip of small screw driver) the recessed switch through the hole in the front panel labeled **Cal- Enable** (to the in position).

Press [BUTTON]:

[ENTER] [7] [9] [3] [1]

[Off] (until display reads 'Calibrate is Test')

[PROG] (to enter Calibration)

Display Reads:

Calibrate is ON
Press OFF key.

Calibrate is Test
Press OFF key.

Cal ACV 5kV Offset
0.050kV

NOTE

Pressing the [↑] key at any time during calibration permits the operator to scroll through the calibration steps.

The [OFF] key enters the operator into that particular calibration step.

The [STOP] key accepts the calibration value.

4.3.2 AC Voltage Calibration

Connect the AC voltmeter between the **HV** and **DRIVE- OUTPUT** terminals.

ACV 5kV Offset & Full:

Press [BUTTON]:



[Off]

[STOP] [TEST]

(Read Voltage from voltmeter. Example: 0.062kV)

[0] [.] [0] [6] [2] [ENTER]

[STOP]



[Off]

[STOP] [TEST]

(Read Voltage from voltmeter. Example: 4.052kV)

[4] [.] [0] [5] [2] [ENTER]

[STOP]

Display Reads:

Cal ACV 5kV Offset 0.050kV

Step-01	0.0s
0.050kV WAC	0.500mA

Step-01	30.0s
---------	-------

Step-01	30.0s
---------	-------

Step-01	0.0s
0.050kV WAC	0.500mA

Cal ACV 5kV Full 4.000kV

Step-01	0.0s
4.000kV WAC	0.500mA

Step-01	30.0s
---------	-------

Step-01	30.0s
---------	-------

Step-01	0.0s
4.000V WAC	0.500mA

4.3.3 DC Voltage Calibration

Connect the DC voltmeter between the **HV** and **DRIVE- OUTPUT** terminals.

DCV 6kV Offset & Full:

Press [BUTTON]:



[Off]

[STOP] [TEST]

(Read Voltage from voltmeter. Example: 0.062kV)

[0] [.] [0] [6] [2] [ENTER]

[STOP]



[Off]

[STOP] [TEST]

(Read Voltage from voltmeter. Example: 4.052kV)

[4] [.] [0] [5] [2] [ENTER]

[STOP]

Display Reads:

Cal DCV 6kV Offset 0.050kV

Step-01	0.0s
0.050kV WDC	0.500mA

Step-01	30.0s
---------	-------

Step-01	30.0s
---------	-------

Step-01	0.0s
0.050kV WDC	0.500mA

Cal DCV 6kV Full 4.000kV

Step-01	0.0s
4.000kV WDC	0.500mA

Step-01	30.0s
---------	-------

Step-01	30.0s
---------	-------

Step-01	0.0s
4.000V WDC	0.500mA

4.3.4 IR Voltage Calibration

Connect the DC voltmeter between the **HV** and **DRIVE- OUTPUT** terminals.

IRV 1kV Offset & Full:

Press [BUTTON]:



[Off]

[STOP] [TEST]

(Read Voltage from voltmeter. Example: 0.062kV)

[0] [.] [0] [6] [2] [ENTER]

[STOP]



[Off]

[STOP] [TEST]

(Read Voltage from voltmeter. Example: 1.052kV)

[1] [.] [0] [5] [2] [ENTER]

[STOP]

Display Reads:

Cal IRV 1kV Offset 0.050kV

Step-01	0.0s
0.050kV IR	1.0M Ω

Step-01	30.0s
---------	-------

Step-01	30.0s
---------	-------

Step-01	0.0s
0.050kV IR	1.0M Ω

Cal IRV 1kV Full 1.000kV

Step-01	0.0s
1.000kV IR	1.0M Ω

Step-01	30.0s
---------	-------

Step-01	30.0s
---------	-------

Step-01	0.0s
1.000kV IR	1.0M Ω

4.3.5 AC Current Calibration

Connect a load resistor (10 MΩ) between the **HV OUTPUT** terminal of the Guardian 6000 and the High terminal of the AC ammeter. Connect the Low terminal of the AC ammeter to the **DRIVE-** terminal (black) of the Guardian 6000.

ACA 3mA Offset/Full:

Press [BUTTON]:



[Off]

[STOP] [TEST]

(Read Current from current meter. Example: 0.124mA)

[0] [.] [1] [2] [4] [ENTER]

[STOP]

(Change Load Resistor to 480kΩ, >50W)



[Off]

[STOP] [TEST]

(Read Current from current meter. Example: 2.903mA)

[2] [.] [9] [0] [3] [ENTER]

[STOP]

Display Reads:

Cal ACA 3mA Offset
0.120mA

Step-01	0.0s
1.200kV WAC	2.999mA

Step-01	30.0s
---------	-------

Step-01	30.0s
---------	-------

Step-01	0.0s
1.200kV WAC	2.999mA

Cal ACA 3mA Full
2.500mA

Step-01	0.0s
1.200kV WAC	2.999mA

Step-01	30.0s
---------	-------

Step-01	30.0s
---------	-------

Step-01	0.0s
1.200kV WAC	2.999mA

ACA 40mA Offset/Full:

Press [BUTTON]:



[Off]

[STOP] [TEST]

(Read Current from current meter. Example: 2.413mA)

[2] [.] [4] [1] [3] [ENTER]

[STOP]

(Change Load Resistor to 45kΩ, >200W)



[Off]

[STOP] [TEST]

(Read Current from current meter. Example: 24.50mA)

[2] [4] [.] [5] [0] [ENTER]

[STOP]

Display Reads:

Cal ACA 40mA Offset 2.50mA

Step-01 0.0s 1.200kV WAC 30.00mA

Step-01 30.0s

Step-01 30.0s

Step-01 0.0s 1.200kV WAC 30.00mA

Cal ACA 40mA Full 25.00mA

Step-01 0.0s 1.200kV WAC 30.00mA

Step-01 30.0s

Step-01 30.0s

Step-01 0.0s 1.200kV WAC 30.00mA

4.3.6 DC Current Calibration

Connect a load resistor (10 M Ω) between the **HV OUTPUT** terminal of the Guardian 6000 and the High terminal of the DC ammeter. Connect the Low terminal of the DC ammeter to the **DRIVE-** terminal (black) of the Guardian 6000.

DCA 3mA Offset/Full:

Press [BUTTON]:



[Off]

[STOP] [TEST]

(Read Current from current meter. Example: 0.124mA)

[0] [.] [1] [2] [4] [ENTER]

[STOP]

(Change Load Resistor to 480k Ω , >50W)



[Off]

[STOP] [TEST]

(Read Current from current meter. Example: 2.413mA)

[2] [.] [4] [1] [3] [ENTER]

[STOP]

Display Reads:

Cal DCA 3mA Offset
0.120mA

Step-01	0.0s
1.200kV WDC	2.999mA

Step-01	30.0s
---------	-------

Step-01	30.0s
---------	-------

Step-01	0.0s
1.200kV WDC	2.999mA

Cal DCA 3mA Full
2.500mA

Step-01	0.0s
1.200kV WDC	2.999mA

Step-01	30.0s
---------	-------

Step-01	30.0s
---------	-------

Step-01	0.0s
1.200kV WDC	2.999mA

DCA 20mA Offset/Full:

Press [BUTTON]:



[Off]

[STOP] [TEST]

(Read Current from current meter. Example: 2.503mA)

[2] [.] [5] [0] [3] [ENTER]

[STOP]

(Change Load Resistor to 80kΩ, >100W)



[Off]

[STOP] [TEST]

(Read Current from current meter. Example: 14.82mA)

[1] [4] [.] [8] [2] [ENTER]

[STOP]

Display Reads:

Cal DCA 20mA Offset 2.50mA

Step-01	0.0s
1.200kV WDC	15.00mA

Step-01	30.0s
---------	-------

Step-01	30.0s
---------	-------

Step-01	0.0s
1.200kV WDC	15.00mA

Cal DCA 20mA Full 12.00mA

Step-01	0.0s
1.200kV WDC	15.00mA

Step-01	30.0s
---------	-------

Step-01	30.0s
---------	-------

Step-01	0.0s
1.200kV WDC	15.00mA

4.3.7 Ground Bond Calibration

Connect a 4 terminal load resistor (10mΩ) between the G6000 (Drive+/Drive-) and (Sense+/Sense-) OUTPUT terminals. Connect an AC voltmeter to Sense+ and Sense- of the load resistor.

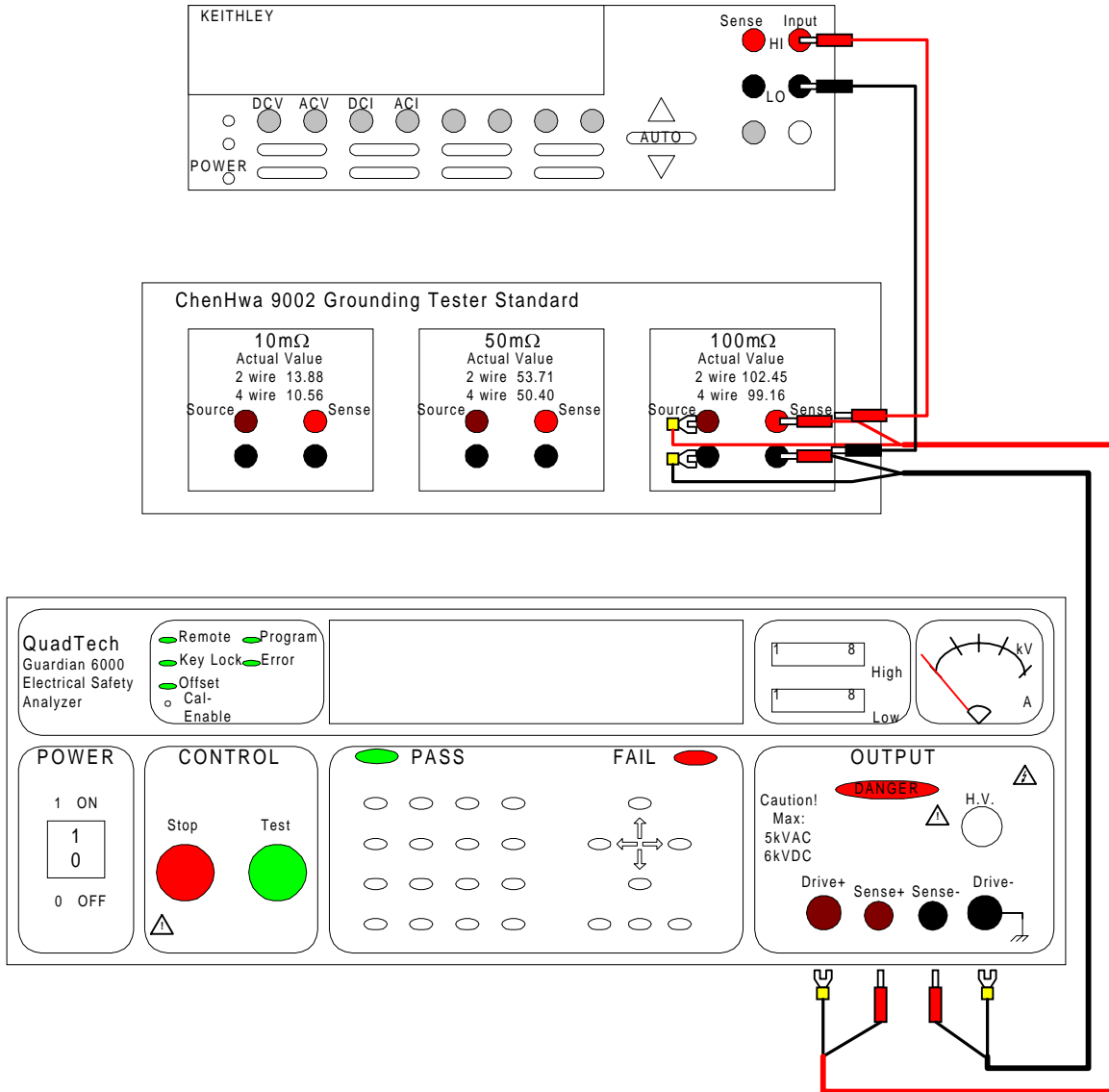

Figure 4-1: Ground Bond Connection

GRA 30A Offset:

Press [BUTTON]:



[Off]

[STOP] [TEST]

(Read Voltage from voltmeter. Calculate current $I = V/R$. Example: 2.897A)

[2] [.] [8] [9] [7] [ENTER]

[STOP]

Display Reads:

Cal GRA 30A Offset
3.00 A

Step-01	0.0s
3.00A	GRA 200.0mΩ

Step-01	30.0s
---------	-------

Step-01	30.0s
---------	-------

Step-01	0.0s
3.00 A	GRA 200.0mΩ

GRA 30A Full:

Change the load resistor to 100mΩ.

Press [BUTTON]:



[Off]

[STOP] [TEST]

(Read Voltage from voltmeter. Calculate current $I = V/R$. Example: 24.87A)

[2] [4] [.] [8] [7] [ENTER]

[STOP]

Display Reads:

Cal GRA 30A Full
25.00 A

Step-01	0.0s
25.00A	GR 200.0mΩ

Step-01	30.0s
---------	-------

Step-01	30.0s
---------	-------

Step-01	0.0s
25.00A	GR 200.0mΩ

GRV 8V Offset:

Change the load resistor to 50mΩ and connect an AC voltmeter to SENSE + and SENSE – terminals of the load resistor.

Press [BUTTON]:



[Off]

[STOP] [TEST]

(Read Voltage from voltmeter. Input voltage value to G6000.)

[3] [.] [0] [1] [5] [ENTER]

[STOP]

Display Reads:

Cal GRV 8V Offset 0.300V

Step-01	0.0s
3.00A	GR 200.0mΩ

Step-01	30.0s
---------	-------

Step-01	30.0s
---------	-------

Step-01	0.0s
3.00A	GR 200.0mΩ

GRV 8V Full:

Change the load resistor to 100mΩ

Press [BUTTON]:



[Off]

[STOP] [TEST]

(Read Voltage from voltmeter. Input voltage value to G6000.)

[3] [0] [.] [0] [5] [ENTER]

[STOP]

Display Reads:

Cal GRV 8V Full 3.000V

Step-01	0.0s
30.00A	GR 200.0mΩ

Step-01	30.0s
---------	-------

Step-01	30.0s
---------	-------

Step-01	0.0s
30.00A	GR 200.0mΩ

4.3.8 WAC and WDC ARcing Calibration

Connect a load resistor of 250kΩ (5 watt). Connect an AC current meter.

NOTE
The arcing calibration range value is 0.1 – 9.9mA.
During calibration the arcing value is changed to ARcing NG.

AC ARC 40mA & DC ARC 20mA:

Press [BUTTON]:

Display Reads:

↑

Cal AC ARC 40mA
5.00mA

[Off]

Step-01 0.0s
1.250kV WAC 10.00mA

[STOP] [TEST]

Step-01 30.0s

(Read Current from current meter. Example: 5.049mA)

[5] [.] [0] [4] [9] [ENTER]

Step-01 30.0s

[STOP]

Step-01 0.0s
1.250kV WAC 10.00mA

↑

Cal DC ARC 20mA
5.00mA

[Off]

Step-01 0.0s
1.250kV WDC 10.00mA

[STOP] [TEST]

Step-01 30.0s

(Read Current from current meter. Example: 5.051mA)

[5] [.] [0] [5] [1] [ENTER]

Step-01 30.0s

[STOP]

Step-01 0.0s
1.250kV WDC 10.00mA

4.3.9 Leakage Current Calibration

4.3.9.1 Simulated LC Calibration

Connect a 500k Ω load resistor between the High (white **HV**) output terminal and the High terminal of an AC/DC ammeter. Connect the Low (black **Drive-**) output terminal to the ammeter Low terminal.

LCA 10mA Offset & Full:

Press [BUTTON]:



[Off]

[STOP] [TEST]

(Read Current from current meter. Example: 0.422mA)

[0] [.] [4] [2] [2] [ENTER]

[STOP]

(Change the load resistor to 100k Ω , >50W)



[Off]

[STOP] [TEST]

(Read Current from current meter. Example: 4.066mA)

[4] [.] [0] [6] [6] [ENTER]

[STOP]

Display Reads:

Cal LCA 10mA Offset 0.400mA

Step-01	0.0s
0.200kV LC	6.00mA

Step-01	30.0s
---------	-------

Step-01	30.0s
---------	-------

Step-01	0.0s
0.200kV LC	6.00mA

Cal LCA 10mA Full 4.000mA

Step-01	0.0s
0.400kV LC	6.00mA

Step-01	30.0s
---------	-------

Step-01	30.0s
---------	-------

Step-01	0.0s
0.400kV LC	6.00mA

4.3.9.2 True LC Calibration (Applicable only if 6000-04 Scanner is Installed)

4.3.9.2.1 LC Current Meter Calibration

Connect the AC voltmeter to the L-IN and N-IN 'LINE INPUT' terminals on the 6000-04 scan unit located on the rear panel of the G6000 unit.

4.3.9.2.1.1 LC 1V Offset & Full:

Press [BUTTON]:



[Off]

[STOP] [TEST]

(Read Voltage from voltmeter. Example: 0.08V)

[0] [.] [0] [8] [ENTER]

[STOP]



[Off]

[STOP] [TEST]

(Read Voltage from voltmeter. Example: 0.8V)

[0] [.] [8] [ENTER]

[STOP]

Display Reads:

Cal	LC	1V	Offset
0.08 V			

Step-01	D1	LO	0.0s
Disable	LC	599.0	uA

Step-01	30.0s
---------	-------

Step-01	30.0s
---------	-------

Step-01	D1	LO	0.0s
Disable	LC	599.0	uA

Cal	LC	1V	Full
0.8 V			

Step-01	D1	LO	0.0s
Disable	LC	599.0	uA

Step-01	30.0s
---------	-------

Step-01	30.0s
---------	-------

Step-01	D1	LO	0.0s
Disable	LC	599.0	uA

4.3.9.2.1.2 LC 10V Offset & Full:

Press [BUTTON]:



[Off]

[STOP] [TEST]

(Read Voltage from voltmeter. Example: 0.8V)

[0] [.] [8] [ENTER]

[STOP]



[Off]

[STOP] [TEST]

(Read Voltage from voltmeter. Example: 8.0V)

[8] [.] [0] [ENTER]

[STOP]

Display Reads:

Cal	LC	10V	Offset
0.8 V			

Step-01	D1	LO	0.0s
Disable	LC	6.000	mA

Step-01	30.0s
---------	-------

Step-01	30.0s
---------	-------

Step-01	D1	LO	0.0s
Disable	LC	6.000	mA

Cal	LC	10V	Full
8 V			

Step-01	D1	LO	0.0s
Disable	LC	6.000	mA

Step-01	30.0s
---------	-------

Step-01	30.0s
---------	-------

Step-01	D1	LO	0.0s
Disable	LC	6.000	mA

4.3.9.2.2 LC Power Meter Calibration

Connect the AC voltmeter to the L-IN and N-IN 'LINE INPUT' terminals on the 6000-04 scan unit located on the rear panel of the G6000 unit.

4.3.9.2.2.1 LCV 300V Offset & Full:

Press [BUTTON]:



[Off]

[STOP] [TEST]

(Read Voltage from voltmeter. Example: 20.0V)

[2] [0] [.] [0] [ENTER]

[STOP]



[Off]

[STOP] [TEST]

(Read Voltage from voltmeter. Example: 200.0V)

[2] [0] [0] [.] [0] [ENTER]

[STOP]

Display Reads:

Cal	LCV	300V	Offset
20 V			

Step-01	D1	LO	0.0s
Disable	LC	6.000	mA

Step-01	30.0s
---------	-------

Step-01	30.0s
---------	-------

Step-01	D1	LO	0.0s
Disable	LC	6.000	mA

Cal	LCV	300V	Full
200 V			

Step-01	D1	LO	0.0s
Disable	LC	6.000	mA

Step-01	30.0s
---------	-------

Step-01	30.0s
---------	-------

Step-01	D1	LO	0.0s
Disable	LC	6.000	mA

Connect an AC current meter to the L-IN and N-IN ‘LINE INPUT’ terminals on the 6000-04 scan unit located on the rear panel of the G6000 unit.

4.3.9.2.2.2 LCA 1A Offset & Full:

Press [BUTTON]:



[Off]

[STOP] [TEST]

(Read Current from current meter. Example:0.08 A)

[0] [.] [0] [8] [ENTER]

[STOP]



[Off]

[STOP] [TEST]

(Read Current from current meter. Example: 0.8 A)

[0] [.] [8] [ENTER]

[STOP]

Display Reads:

Cal	LCA	1A	Offset
0.08 A			

Step-01	D1	LO	0.0s
0.900 A	LC	6.000 mA	

Step-01	30.0s
---------	-------

Step-01	30.0s
---------	-------

Step-01	D1	LO	0.0s
0.900 A	LC	6.000 mA	

Cal	LCV	1A	Full
0.8 A			

Step-01	D1	LO	0.0s
0.900 A	LC	6.000 mA	

Step-01	30.0s
---------	-------

Step-01	30.0s
---------	-------

Step-01	D1	LO	0.0s
0.900 A	LC	6.000 mA	

4.3.9.2.2.3 LCA 10A Offset & Full:

Press [BUTTON]:



[Off]

[STOP] [TEST]

(Read Current from current meter. Example:0.8 A)

[0] [.] [8] [ENTER]

[STOP]



[Off]

[STOP] [TEST]

(Read Current from current meter. Example: 8 A)

[8] [.] [0] [ENTER]

[STOP]

Display Reads:

Cal	LCA	10A	Offset
0.8 A			

Step-01	D1	LO	0.0s
10.00 A	LC	6.000	mA

Step-01	30.0s
---------	-------

Step-01	30.0s
---------	-------

Step-01	D1	LO	0.0s
10.00 A	LC	6.000	mA

Cal	LCV	10A	Full
8 A			

Step-01	D1	LO	0.0s
10.00 A	LC	6.000	mA

Step-01	30.0s
---------	-------

Step-01	30.0s
---------	-------

Step-01	D1	LO	0.0s
10.00 A	LC	6.000	mA

4.3.10 IR Resistor Calibration

IRR Range 0 and Range 1:

Connect a 1GΩ load resistor between the HIGH (HV) and LOW (Drive-) terminals of the G6000 instrument.

NOTE

Upon entering the calibrated value of the resistance standard, the G6000 unit may respond with a low limit failure. (FAIL LED lights, Display indicates “low limit failure”).

This is normal. Proceed with remaining calibration steps.

Press [BUTTON]:

Display Reads:

↑

Cal IRR Range0
1.00GΩ

[Off]

Step-01 0.0s
0.250kV IR 1.0MΩ

[STOP] [TEST]

Step-01 30.0s

(Enter calibrated value of Resistance Standard. Example: 1000.01M)

[1] [0] [0] [0] [.] [0] [1] [ENTER]

Step-01 30.0s

[STOP]

Step-01 0.0s
0.250kV IR 1.0MΩ

(Change the load resistor to 100MΩ)

↑

Cal IRR Range1
100.0MΩ

[Off]

Step-01 0.0s
0.500kV IR 1.0MΩ

[STOP] [TEST]

Step-01 30.0s

(Enter calibrated value of Resistance Standard. Example: 100.01M)

[1] [0] [0] [.] [0] [1] [ENTER]

Step-01 30.0s

[STOP]

Step-01 0.0s
0.500kV IR 1.0MΩ

IRR Range 2 and Range 3:
Change the load resistor to 10MΩ

Press [BUTTON]:

Display Reads:

↑

Cal IRR Range2 10.0MΩ

[Off]

Step-01	0.0s
0.500kV IR 1.0MΩ	

[STOP] [TEST]

Step-01	30.0s
---------	-------

(Enter calibrated value of Resistance Standard. Example: 10.01M)

[1] [0] [.] [0] [1] [ENTER]

Step-01	30.0s
---------	-------

[STOP]

Step-01	0.0s
0.500kV IR 1.0MΩ	

(Use the same 10MΩ load resistor)

↑

Cal IRR Range3 10.0MΩ

[Off]

Step-01	0.0s
1.000kV IR 1.0MΩ	

[STOP] [TEST]

Step-01	30.0s
---------	-------

(Enter calibrated value of Resistance Standard. Example: 10.01M)

[1] [0] [.] [0] [1] [ENTER]

Step-01	30.0s
---------	-------

[STOP]

Step-01	0.0s
1.000kV IR 1.0MΩ	

4.3.11 Finalize Calibration

When all calibration steps are complete:

Press [BUTTON]:

[ENTER] [7] [9] [3] [1]

[Off] (until display reads 'Calibrate is ON')

[PROG] (to exit Calibration)

Display Reads:

Calibrate is Test Press OFF key.

Calibrate is ON Press OFF key.

Step-01	0.0s
1.000kV WAC	3.0mA

Press the lock switch labeled [Cal-Enable] (to the out position) and cover with a calibration label.

NOTE

Pressing the [↑] key at any time during calibration permits the operator to scroll through the calibration steps.

The [OFF] key enters the operator into that particular calibration step.

The [STOP] key accepts the calibration value.

4.4 Error Messages

Possible error messages for the Guardian 6000 Series instrument family are divided into two categories. There is a set of error messages that apply to the normal operation of the instrument and a second set of error messages that apply to the operation of the instrument with a GPIB (IEEE-488) Interface installed. Refer to Table 4-3.

Table 4-3: Error Messages

Operation	Error Number	Message Description
Normal	100	HARDWARE FAILURE
	101	Consult QuadTech for SERVICE
	102	
	Discharging	
GPIB	Error 0	Save OK!
	Error 1	The command is INVALID!
	Error 2	The parameter is INVALID!
	Error 3	TEST can NOT be initiated!
	Error 4	Scan Box is NOT CONNECTED!
	Error 5	Can NOT set Channel # to ZERO!
	Error 6	Set Channel HIGH OR LOW, NOT BOTH!
	Error 7	No DATA to RECALL! (No Data stored in recall location)
	Error 8	No MEMORY for STORAGE! (Invalid memory location)